

Operating Instructions

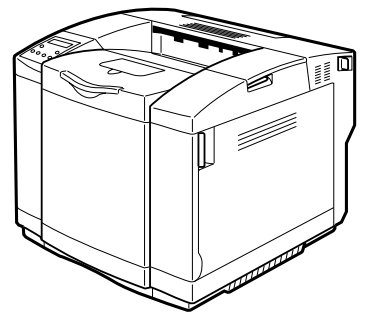

Read this manual carefully before you use this product and keep it handy for future reference. For safe and correct use, please be sure to read the Safety Information in the Setup Guide before using the machine.

Introduction

This manual describes detailed instructions on the operation and notes about the use of this machine. To get maximum versatility from this machine all operators are requested to read this manual carefully and follow the instructions. Please keep this manual in a handy place near the machine.

Important

Contents of this manual are subject to change without prior notice. In no event will the company be liable for direct, indirect, special, incidental, or consequential damages as a result of handling or operating the machine.

Caution:

Use of controls or adjustment or performance of procedures other than those specified in this manual might result in hazardous radiation exposure.

Do not attempt any maintenance or troubleshooting other than that mentioned in this manual. This printer contains a laser beam generator and direct exposure to laser beams can cause permanent eye damage.

Notes:

Some illustrations in this manual might be slightly different from the machine.

Certain options might not be available in some countries. For details, please contact your local dealer.

For good print quality, the supplier recommends that you use genuine toner, maintenance kits and parts from the supplier.

The supplier shall not be responsible for any damage or expense that might result from the use of consumables (toner, maintenance kits and parts) other than genuine consumables from the supplier with your office products.

Trademarks

Microsoft, Windows and Windows NT are registered trademarks of Microsoft Corporation in the United States and/or other countries.

IPS-PRINT Printer Language Emulation Copyright© 1999-2000 Oak Technology, Inc., All rights reserved.

Other product names used herein are for identification purposes only and might be trademarks of their respective companies. We disclaim any and all rights in those marks.

The proper names of the Windows operating systems are as follows:

- The product name of Windows® 95 is Microsoft® Windows® 95.
- The product name of Windows® 98 is Microsoft® Windows® 98.
- The product name of Windows® Me is Microsoft® Windows® Millennium Edition (Windows Me).
- The product names of Windows® 2000 are as follows:
 - Microsoft® Windows® 2000 Advanced Server
 - Microsoft® Windows® 2000 Server
 - Microsoft® Windows® 2000 Professional
- The product names of Windows® XP are as follows:
 - Microsoft® Windows® XP Professional
 - Microsoft® Windows® XP Home Edition
- The product names of Windows Server™ 2003 are as follows:
 - Microsoft® Windows Server™ 2003 Standard Edition
 - Microsoft® Windows Server™ 2003 Enterprise Edition
 - Microsoft® Windows Server™ 2003 Web Edition
- The product names of Windows NT® 4.0 are as follows:
 - Microsoft® Windows NT® Server 4.0
 - Microsoft® Windows NT® Workstation 4.0

Table of Contents

Chapter 1 Basic Operations	1-1
1. Turning On and Off.....	1-2
2. Loading Paper Trays with Print Media	1-4
3. Setting the Printer Driver	1-9
Chapter 2 Replacing Consumables	2-1
1. Consumables.....	2-2
2. Replacing the Toner Cartridge	2-3
3. Replacing the Belt Cartridge.....	2-5
4. Replacing the Waste Toner Pack.....	2-8
Chapter 3 Maintenance.....	3-1
1. Cleaning the Registration Roller.....	3-2
Chapter 4 Control Panel	4-1
1. Functions of LCD and Lamps	4-2
2. Messages	4-3
3. Functions of Control Keys	4-10
Chapter 5 Panel Menu Functions.....	5-1
1. Panel Menu Overview	5-2
2. Operating Panel Menus.....	5-4
3. Test Menu.....	5-6
4. Config Menu	5-14
Chapter 6 Troubleshooting	6-1
1. Media Jams	6-2
2. Actions on Print Quality Problems.....	6-16
3. Actions on Incorrect Print Results	6-18
4. Actions on Abnormal Printer Operation.....	6-20

Appendixes	A-1
Appendix A Specifications	A-2
Appendix B Consumables	A-4
Appendix C Print Area	A-6
Appendix D Notes on Moving the Printer	A-7
Appendix E Checking Printer's Versions	A-8

Chapter 1 Basic Operations

- 1. Turning On and Off-----1-2
- 2. Loading Paper Trays with Print Media -----1-4
- 3. Setting the Printer Driver -----1-9

1. Turning On and Off

1.1 Turning On the Printer

Turn on the printer according to the procedure below.

When you turn off and turn on the printer power successively, wait five seconds or more before turning on the power.

Procedure for turning on the printer

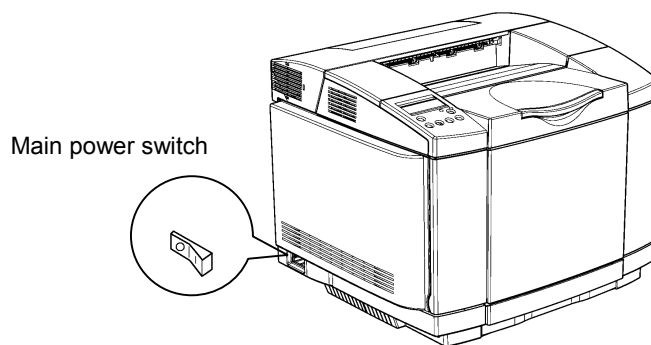

- (a) Press the main power switch of the printer to turn the printer power on.
- (b) If the printer power does not turn on, see “4. Actions on Abnormal Printer Operation” in Chapter 6 on this manual.

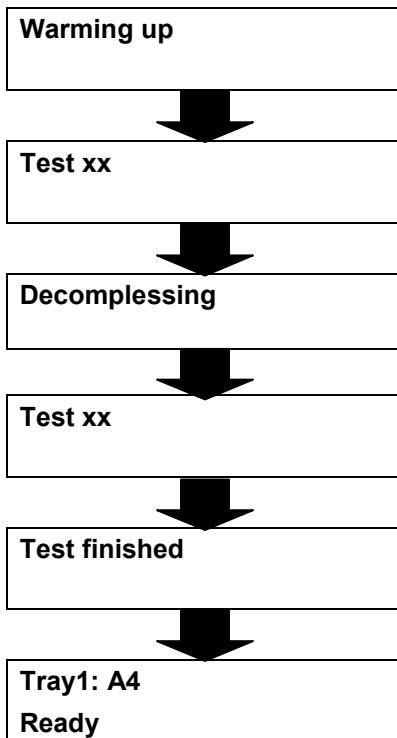

- (c) When you turn on the printer, ensure that the LCD in the control panel displays the information shown left.

— If a printer error is detected: —

If a printer error is detected, the ERROR lamp in the control panel turns on, and the display provides an error message.

For details of error messages and actions to be taken, see “2. Messages” in Chapter 4 on this manual.

1.2 Turning Off the Printer

Turn off the printer according to the procedure below.

Procedure for turning off the printer

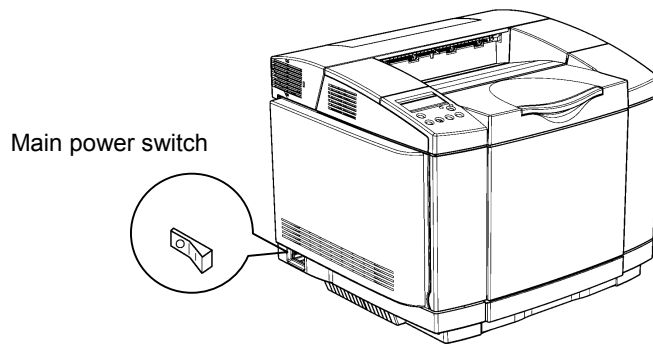

- (a) Check that the printer is not operating.
After printing data or after closing the cover, wait for the operational noise to stop.
- (b) Turn off the main power switch of the printer.

2. Loading Paper Trays with Print Media

2.1 Print Media Guidelines

Use proper print media to maximize the performance of the printer.

2.1.1 Print Media Specifications

The tables below show the specifications of the print media by paper tray and print mode.

Tray 1 in Simplex Print

Media type	Media specifications	Tray capacity	Media size (W × L)
Plain paper	For laser printer Mass: 60 to 90 g/m ² , 16 to 24 lb. bond	About 250 sheets	A4: 210 × 297 (mm), 8.27 × 11.69 (inch) A5: 148.5 × 210 (mm), 5.83 × 8.27 (inch)
Thick paper	For laser printer Mass: 90 to 210 g/m ² , 24 to 55 lb. bond	About 40 sheets	B5 (ISO): 176 × 250 (mm), 6.93 × 9.84 (inch)
Label	For laser printer Capable of continuous formfeed	About 80 sheets	B5 (JIS): 182 × 257 (mm), 7.17 × 10.12 (inch) Letter: 215.9 × 279.4 (mm), 8½ × 11 (inch) Half Letter: 139.7 × 215.9 (mm), 5½ × 8½ (inch) Executive: 184.2 × 266.7 (mm), 7¼ × 10½ (inch) Legal*: 215.9 × 355.6 (mm), 8½ × 14 (inch) Custom**: 104.8 to 215.9 × 210 to 297 or 355.6 (mm), 4.13 to 8.50 × 8.27 to 11.69 or 14.00 (inch)
OHP film (transparency)	For laser printer	About 50 sheets	A4: 210 × 297 (mm), 8.27 × 11.69 (inch) Letter: 215.9 × 279.4 (mm), 8½ × 11 (inch)
Envelope***	Non-flap side only	About 15 sheets (excluding H/H condition)	Commercial #10: 104.8 × 241.3 (mm), 4¼ × 9½ (inch) International DL: 110 × 220 (mm), 4.33 × 8.66 (inch)

* Requires optional paper tray capable of loading up to legal size media.

** Max. length of custom media size is 297 (mm)/11.69 (inch) for standard paper tray and 355.6 (mm)/14.00 (inch) for optional paper tray capable of loading up to legal size media.

*** Check there is no air in the envelopes before loading.

Before loading envelopes, flatten their leading edges (the edge going into the printer) by running a pencil or ruler across them.

Some kinds of envelope might cause misfeeds, wrinkles or print poorly.

Tray 2 in Simplex Print

Media type	Media specifications	Tray capacity	Media size (W × L)
Plain paper	For laser printer Mass: 60 to 90 g/m ² , 16 to 24 lb. bond	About 530 sheets	A4: 210 × 297 (mm), 8.27 × 11.69 (inch) B5 (ISO): 176 × 250 (mm), 6.93 × 9.84 (inch)
Thick paper	For laser printer. Mass: 90 to 105 g/m ² , 24 to 28 lb. bond		B5 (JIS): 182 × 257 (mm), 7.17 × 10.12 (inch) Letter: 215.9 × 279.4 (mm), 8 ¹ / ₂ × 11 (inch) Executive: 184.2 × 266.7 (mm), 7 ¹ / ₄ × 10 ¹ / ₂ (inch)

Duplex Print

Media type	Media specifications	Media size (W × L)
Plain paper	For laser printer Mass: 60 to 90 g/m ² , 16 to 24 lb. bond	A4: 210 × 297 (mm), 8.27 × 11.69 (inch) B5 (ISO): 176 × 250 (mm), 6.93 × 9.84 (inch) B5 (JIS): 182 × 257 (mm), 7.17 × 10.12 (inch)
Thick paper	For laser printer Mass: 90 to 105 g/m ² , 24 to 28 lb. bond	Letter: 215.9 × 279.4 (mm), 8 ¹ / ₂ × 11 (inch) Executive: 184.2 × 266.7 (mm), 7 ¹ / ₄ × 10 ¹ / ₂ (inch) Legal*: 215.9 × 355.6 (mm), 8 ¹ / ₂ × 14 (inch) Custom: 104.8 to 215.9 × 210 to 297 (mm), 4.13 to 8.50 × 8.27 to 11.69 (inch)

* Applicable only to optional paper tray capable of loading up to legal size media in Tray 1.

2.1.2 Paper not supported by this printer

Avoid using the following paper as they are not supported by this printer.

- Paper meant for an ink-jet printer
- Bent, folded, or creased paper
- Curled or twisted paper
- Torn paper
- Wrinkled paper
- Damp paper
- Paper that is dry enough to emit static electricity
- Paper that has already been printed onto, except a preprinted letterhead Malfunctions are especially likely when using paper printed on by other than a laser printer (e.g. monochrome and color copiers, ink-jet printers, etc.).
- Special paper, such as thermal paper, aluminum foil, carbon paper and conductive paper
- Paper whose weight is heavier or lighter than the limitation.
- Paper with windows, holes, perforations, cutouts, or embossing
- Adhesive label paper on which glue or base paper is exposed
- Paper with clips or staples

2.2 Supplying Print Media

Shown below is an example for Tray1. It is also applicable to Tray2.

When DATA lamp is blinking, do not draw the paper tray from the printer. It may cause a jam.

Procedure for setting media

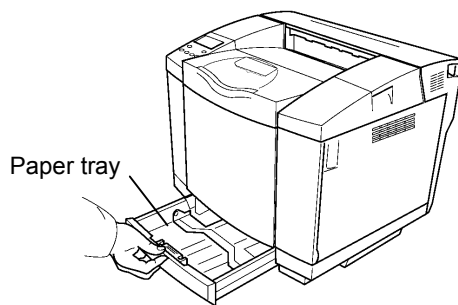

- (a) Draw out the paper tray from the printer.

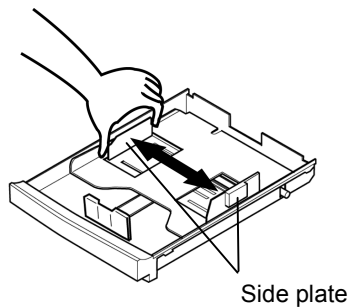

- (b) Hold the stopper on the pair of side plates, and adjust it to fit the width of the media.

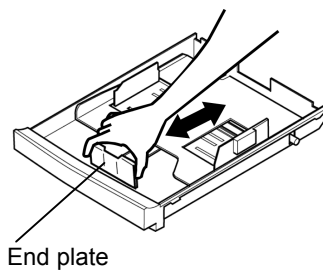

- (c) Hold the stopper on the end plate, and adjust it to fit the length of the media.

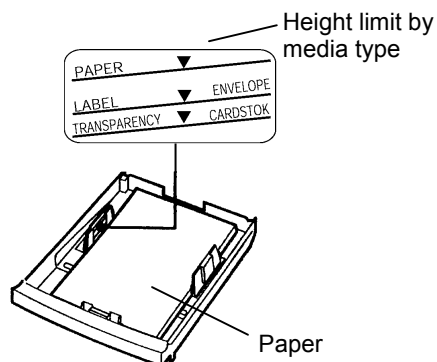

- (d) Supply paper (A4-size plain paper in this example) in the paper tray. Pay attention to the following:
- Check that the four corners of the paper are set firmly in the paper tray.
 - Supply an appropriate amount of paper so that it does not exceed its height limit.

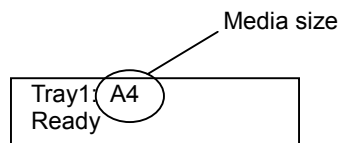
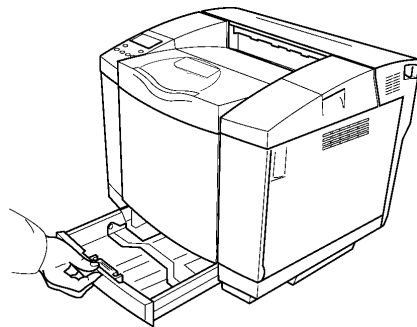

(e) Re-mount the paper tray into the printer.

(f) Check the media size displayed on the control panel. For details of the media size display, see “2.1 LCD display” in Chapter 4 on this manual. For the custom size, a size menu in proximity appears.

If ‘---’ appears as the media size, the media are not correctly placed. Place the media again.

————— Note on height limit for print media —————

The height limit for print media varies with the paper tray as shown below. Be sure to load the print media within the height limit.

Height limit indication on Tray1

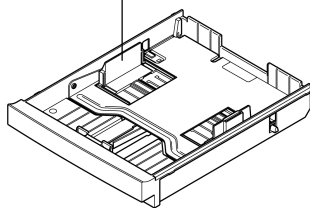
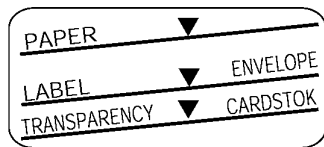

Height limit indication on Tray2

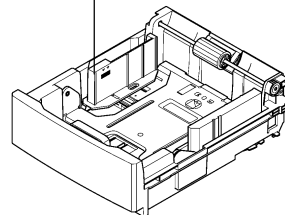
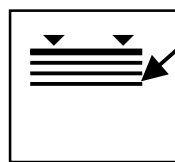

Height limit for Tray1 by media type:

- Plain paper: Up to PAPER
- Thick paper and label: Up to LABEL
- Transparency: Up to TRANSPARENCY
- Envelope: Up to ENVELOPE

3. Setting the Printer Driver

Set the printer driver so that the following functions at printing are specified. See the printer driver help for further information.

Item on dialog box	Function
Paper Source (page 1-10)	Specifies the input tray.
Paper Type (page 1-11)	Specifies the type of print media.
Display at Paper Changing (page 1-13)	Specifies whether to stop printing for a moment to change paper by displaying a default message or a user-defined message on the control panel when the printer receives the print data.
Orientation	Specifies the printing orientation.
Layout	Specifies the page layout (column printing).
Duplex Print (page 1-12)	Specifies whether to perform duplex print.
Margins	Specifies the position and width of margins.
Print Mode (page 1-14)	Sets the print mode (Standard, High Speed, or High Quality).
Color Mode (page 1-15)	Sets the color mode to Document, Photographs, Graphics, B&W, and Custom Setting (user definition that can be registered).
Density	Specifies the density of each color (black, cyan, magenta, and yellow).
Black Generation	Specifies whether to generate black by single color (black) or by a mix of three colors (cyan, magenta, and yellow).
Save Toner	Specifies whether to save toner at printing.

3.1 Setting the Paper Source

Select one of the Paper Source settings on the printer driver according to the target input tray as shown below. See the printer driver help for further information. You may also specify the input tray from the application software.

Procedure for setting the Paper Source (Example with Windows® 2000)

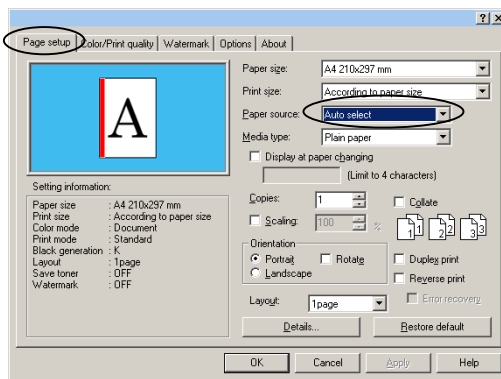

- (a) Open the printer properties and click the Page Setup tab.
- (b) Select Paper Source according to the target input tray.
 - Auto Select: Automatically selects the input tray containing media of the specified size with the priority of Tray1>Tray2.
 - Tray1 or Tray2: Selects the specified input tray.
- (c) Click the OK button to validate your settings.

Notes on paper feeding

- If no Paper Feeder option is installed, the print media are fed only from Tray1.
- A5, Half Letter, Commercial #10, International DL, or Custom size media are only fed from Tray1. Legal size media are only fed from Tray1 of the optional input tray for up to Legal media sizes.
- If the Media Type setting on the printer driver is Label, Transparency, Thick1, Thick2, Special or Envelope, the print media are fed only from Tray1. (page 1-11)

3.2 Setting the Media Type

Select one of the Media Type settings on the printer driver according to the target type of print media. See the printer driver help for further information.

Procedure for setting the Media Type (Example with Windows® 2000)

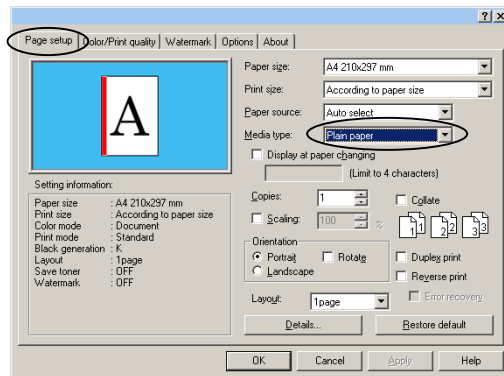

- (a) Open the printer properties and click the Page Setup tab.
- (b) Select Media Type according to the target media type.
- (c) Click the OK button to validate your settings.

Notes on setting the Media Type

- For details about the types of print media available for the printer, see "2.1 Print Media Guidelines" on page 1-4.
- Difference between the type of actual print media and that of the printer driver setting deteriorates the print quality. To work around such difference, it is recommended that you check the printer driver's Display at Paper Changing checkbox. (page 1-13)

3.3 Duplex Printing

To print with the Duplex Unit option on both sides of the sheet, it is necessary to specify the duplex print on the printer driver according to the procedure below.

See the printer driver help for further information.

Procedure for duplex printing (Example with Windows® 2000)

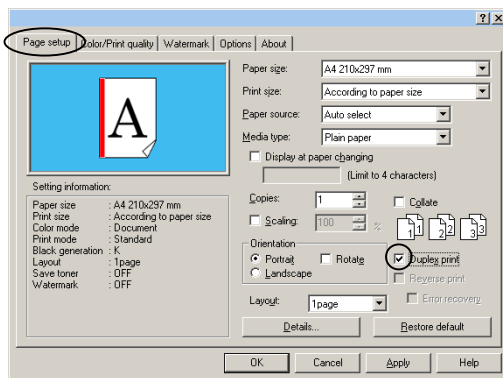

- (a) Open the printer properties and click the Page Setup tab.
- (b) Check the Duplex Print checkbox.
- (c) Click the OK button to validate your settings.

Notes on duplex printing

In any of the following cases, the printer performs simplex print regardless of the above setting.

- When the Duplex Unit option is not installed.
- When the Media Type setting is Label, Transparency, Thick1, Thick2, Special or Envelope. (page 1-11)
- When the Paper Size setting is A5, Half Letter, Commercial #10, International DL, or Custom.

3.4 Changing the Media before Starting Print (Pause Function)

You can use the “Display at Paper Changing” function of the printer driver to pause the printer and replace the media in the paper tray before starting print. Use this function when:

- ◆ you are not sure if the paper tray may contain the applicable media; or
- ◆ you want to ensure the media in the paper tray immediately before starting print.

Particularly, if you have changed the media type (page 1-11) or if you want to print a document of a custom size, this function is recommended for prevention of inadvertent print on a wrong media.

The procedure is shown below. See the printer driver help for further information.

Procedure for changing the media before starting print (Example with Windows® 2000)

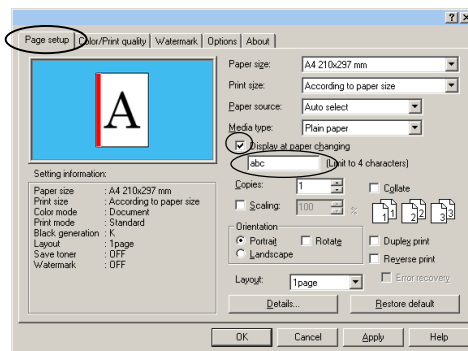

- Open the printer properties and click the Page Setup tab.
- Check the Display at Paper Changing checkbox.
- Enter userid or similar identification consisting of four or fewer characters.
- Click the OK button to validate your settings.
- When the printer receives this print data, the printer is stopped and the control panel displays the message as shown left.

Note: This example assumes that the input tray is Tray 1, the paper size is A4, the media type is OHP film (transparency), and the identification input by the user is abc.

Change Tray 1
A4 (Trans): abc

- Remove the paper tray corresponding to the control panel display. (page 1-7)
- Then, prepare a new paper tray loaded with the target media, replace the media in the removed tray, or just ensure the media in the removed tray.
- Insert the paper tray into the printer, and printing will start.

Notes:

- Before removing the paper tray, you can start printing by pressing any key on the control panel other than ONLINE and CLEAR.
- This pause function supersedes the functions covered in “3. Functions of Control Keys” in Chapter 4 on this manual.

3.5 Setting the Print Mode

Select one of the Print Mode settings on the printer driver according to the procedure below. See the printer driver help for further information.

Procedure for setting the print mode (Example with Windows® 2000)

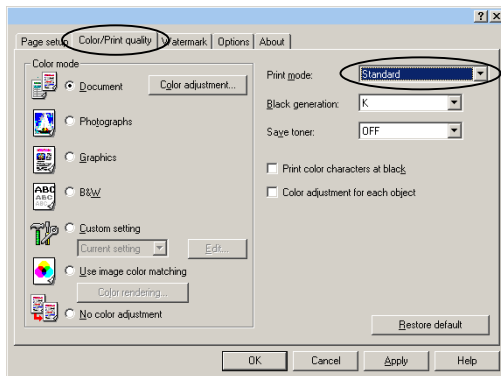

- (a) Open the printer properties and click the Color/Print quality tab.
- (b) Select Print mode according to the target media type: as follows:
 - High Speed: high print speed, low print quality
 - Standard: medium print speed, medium print quality
 - High Quality: low print speed, high print quality
- (c) Click the OK button to validate your settings.

3.6 Setting the Color Mode

Select one of the color mode settings according to the procedure below. See the printer driver help for further information.

Procedure for setting the color mode (Example with Windows® 2000)

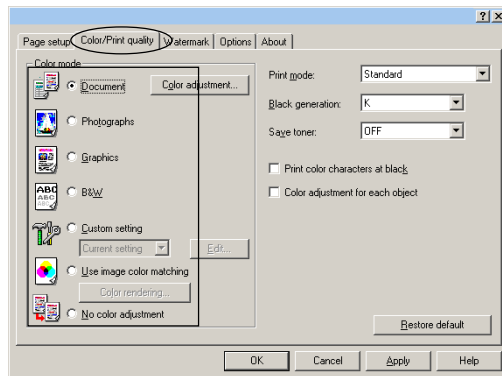

- (a) Open the printer properties and click the Color/Print quality tab.
- (b) Choose an option in Color Mode as follows:
 - Document: Prints general documents in color.
 - Photographs: Prints realistic color photographs.
 - Graphics: Prints vivid color graphics.
 - B&W: Prints in black and white.
 - Custom Setting: Registers and prints with user-defined color adjustment.
 - Use Image Color Matching: Prints with Image Color Matching enabled under Windows® 98 or later.
 - No Color Adjustment: Prints without color adjustment.
- (c) Click the OK button to validate your settings.

Chapter 2 Replacing Consumables

- 1. Consumables-----2-2**
- 2. Replacing the Toner Cartridge-----2-3**
- 3. Replacing the Belt Cartridge -----2-5**
- 4. Replacing the Waste Toner Pack -----2-8**

1. Consumables

The printer has the following consumables.

■ Toner cartridges

- Black (K)
- Yellow (Y)
- Magenta (M)
- Cyan (C)

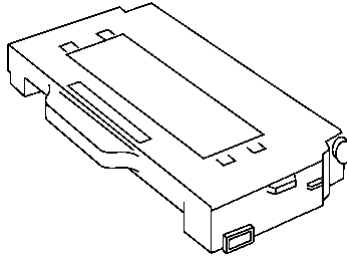

■ Belt cartridge

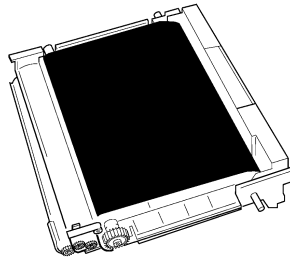

■ Waste toner pack

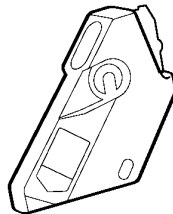

In this manual, the "Photo Conductor Unit Type 140" is called the "Belt cartridge" and the "Waste Toner Bottle Type 140" is called the "Waste toner pack".

2. Replacing the Toner Cartridge

Replace the toner cartridge according to the procedure below.

WARNING

- Do not incinerate spilled toner or used toner. Toner dust is flammable and might ignite when exposed to an open flame.
- Disposal should take place at an authorized dealer or an appropriate collection site.
- If you dispose of the used toner cartridges yourself, dispose of them according to local regulations.

CAUTION

Keep toner (used or unused) and the toner cartridge out of reach of children.

Note on replacing the toner cartridge

Handle the toner cartridge with its label facing upward. Do not stand or reverse the toner cartridge.

Procedure for replacing the toner cartridge

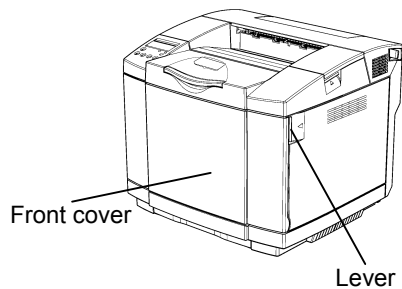

- (a) Unlock the lever on the front cover and open the front cover.

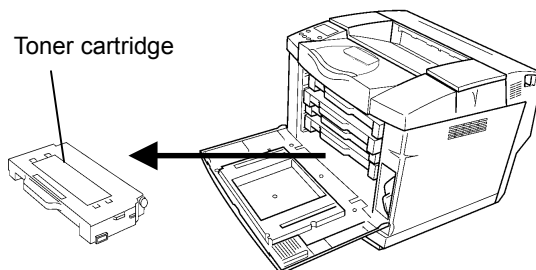

- (b) Draw out the exhausted toner cartridge horizontally, paying attention not to spill the toner. Do not handle more than one toner cartridge at the same time.

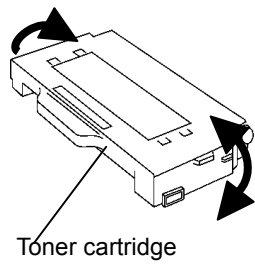

- (c) Gently rock a new toner cartridge three or four times in the direction of arrows to level out the toner inside the cartridge.

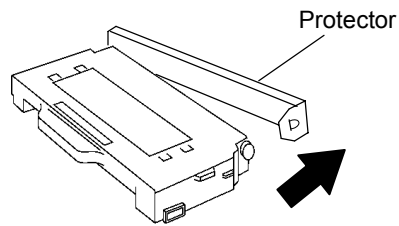

- (d) Peel off the tape, and remove the protector for the toner cartridge from the right. Do not lose the protector because it is necessary for transporting the printer.

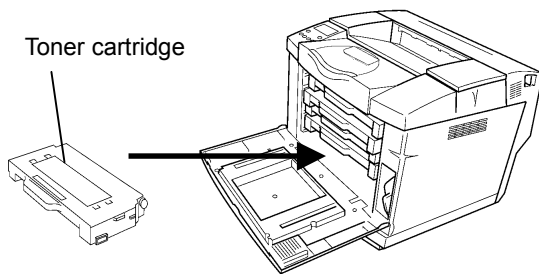

- (e) Softly force the toner cartridge along the guides in the printer.

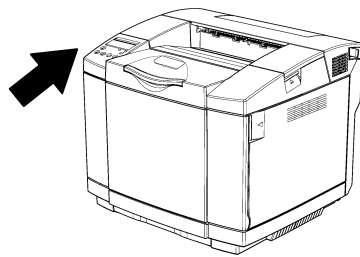

- (f) Close the front cover securely by pushing it until it locks.

3. Replacing the Belt Cartridge

Replace the belt cartridge according to the procedure below.

WARNING

- Disposal should take place at an authorized dealer or an appropriate collection site.
- If you dispose of the used belt cartridge yourself, dispose of it according to local regulations.

Notes on replacing the belt cartridge

- Exposing the photo conductor unit to light for too long can reduce its performance. Replace the unit as quickly as possible.
- Be sure to make the setting from the control panel after replacing the photo conductor unit. Without it, the procedure is incomplete.

Procedure for replacing the belt cartridge

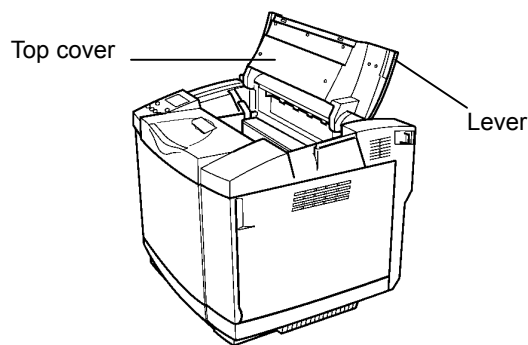

- (a) Pull up the lever on the top cover and open the top cover, and open the top cover until it stops.
- **Keep the top cover fully open during the replacement work.**

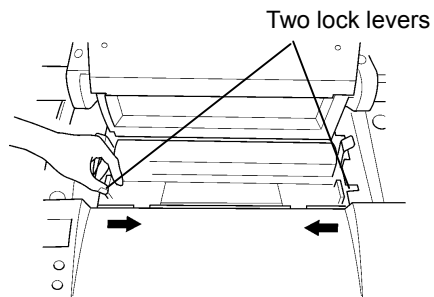

- (b) Pull up the two green lock levers.

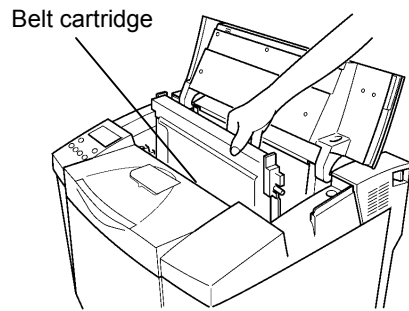

- (c) Draw out the exhausted belt cartridge straight up.
- **Pay attention not to spill any toner onto the drawn belt cartridge.**

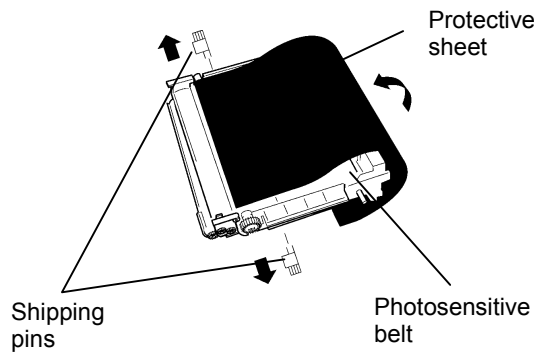

- (d) Remove the two shipping pins of a new belt cartridge.
- (e) Remove the protective sheet for the belt cartridge. Pay attention to the following:
- **Do not touch the photosensitive belt.**
 - **Do not wipe off any of the white powder adhering to the photosensitive belt.**

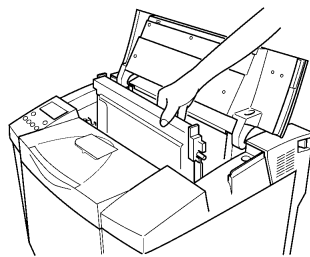

- (f) With the photosensitive belt facing front, slide the belt cartridge into the printer along the guide for the lock lever.

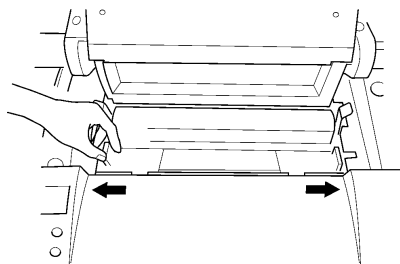

- (g) Restore the lock levers .

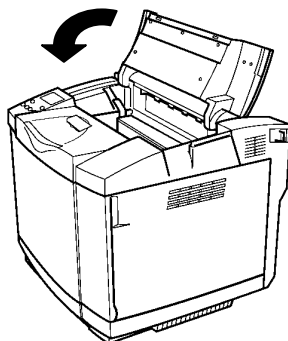

- (h) Close the top cover by pushing it until it locks.
- **While closing, keep holding the top cover until you close it to the locked position.**

● Panel operation after replacing the belt cartridge

(i) Ensure that “Ready” is displayed on the LCD.

**Tray1: A4
Ready**

(j) Press ONLINE key. The ONLINE lamp goes out when the printer enters offline mode.

**Tray1: A4
Not Ready**

(k) Press MENU key. Keep pressing MENU key for three seconds. Utility Menu appears after Test menu appeared.

**Tray1: A4
Utility Menu**

(l) Press ENTER key. Clear Belt CG submenu appears.

**Utility Menu
Clear Belt CG**

(m) Press ENTER key, and the Not Execute appears.

**Clear Belt CG
Not Execute**

(n) Press ◀ or ▶ key proper times until the Execute option appears.

**Clear Belt CG
Execute**

(o) Press ENTER key to execute the clear Belt CG, display Completed.

**Completed
Clear Belt CG**

(p) Press ONLINE key to terminate the menu operation and cause the printer to enter online mode.

4. Replacing the Waste Toner Pack

Replace the waste toner pack according to the procedure below.

 WARNING
<ul style="list-style-type: none">● Do not incinerate spilled toner or used toner. Toner dust is flammable and might ignite when exposed to an open flame.● Disposal should take place at an authorized dealer or an appropriate collection site.● If you dispose of the used waste toner pack yourself, dispose of it according to local regulations.

Procedure for replacing the waste toner pack

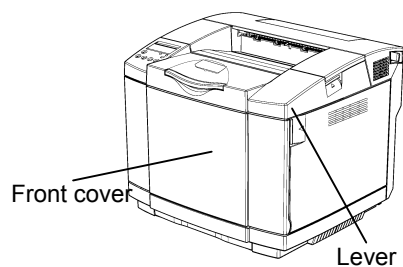

- (a) Unlock the lever on the front cover and open the front cover.

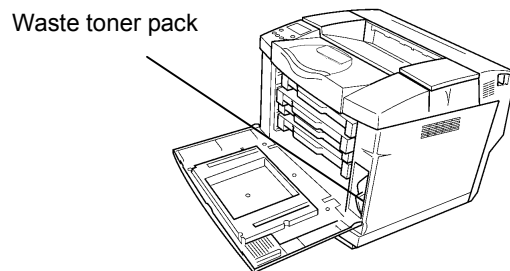

- (b) Remove the filled waste toner pack from the printer.

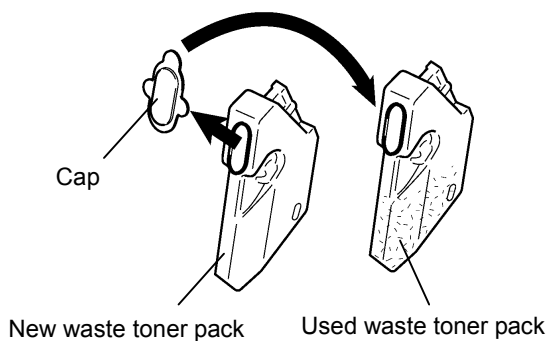

- (c) Prepare a new waste toner pack and remove the cap.

With this removed cap, seal the inlet of the removed waste toner pack .

- **To prevent waste toner from leaking, place the waste toner pack into the polyethylene bag that came with the new waste toner pack, and seal the bag.**

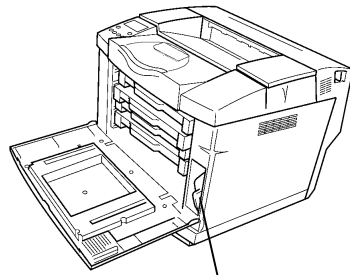

Waste toner pack

- (d) Place the new waste toner pack into the printer.

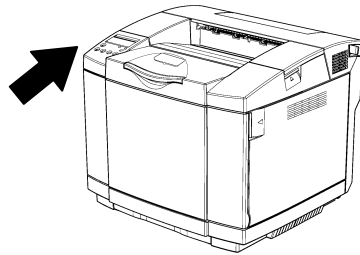

- (e) Close the front cover securely by pushing it until it locks.

Chapter 3 Maintenance



- 1. Cleaning the Registration Roller -----3-2**

1. Cleaning the Registration Roller

WARNING

- Do not remove any covers or screws other than those specified in this manual. Some parts of the machine are at a high voltage and could give you an electric shock. Also, if the machine has laser systems, direct (or indirect) reflected eye contact with the laser beam may cause serious eye damage. When the machine needs to be checked, adjusted, or repaired, contact your service representative.
- Do not take apart or attempt any modifications to this machine. There is a risk of fire, electric shock, explosion or loss of sight. If the machine has laser systems, there is a risk of serious eye damage.

CAUTION

The inside of the machine be-comes very hot. Do not touch the parts with a “” label (means hot surface). Touching a part with a “” label (means hot surface) could result in a burn.

Clean the registration roller when black or white dots caused by bits of paper stuck to the roller become obvious on printed OHP transparencies

Cleaning procedure

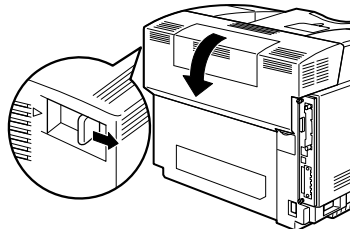

- (a) Pull the rear cover open lever, and then open the rear cover.

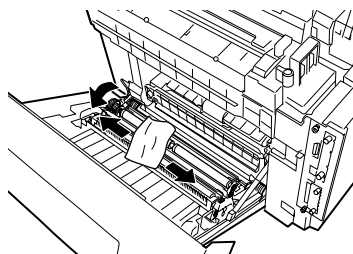

- (b) Wipe the registration roller with a dry cloth while slowly turning it.

- (c) Close the rear cover.

Chapter 4 Control Panel

- 1. Functions of LCD and Lamps -----4-2**
- 2. Messages -----4-3**
- 3. Functions of Control Keys ----- 4-10**

1. Functions of LCD and Lamps

One LCD (liquid crystal display) and two lamps on the control panel indicate the state of the printer as illustrated below.

LCD (16 characters x 2 rows):
Displays messages relating to the state of the printer.

ERROR lamp (Orange):
Lit when any message relating to disability of printing is displayed.

ONLINE lamp (Green):
Lit when print data can be received (or in automatic or forced online status), and turned off when print data cannot be received (or in automatic or forced offline status). Forced status change is performed by the ONLINE key (page 4-10) just below this ONLINE lamp.

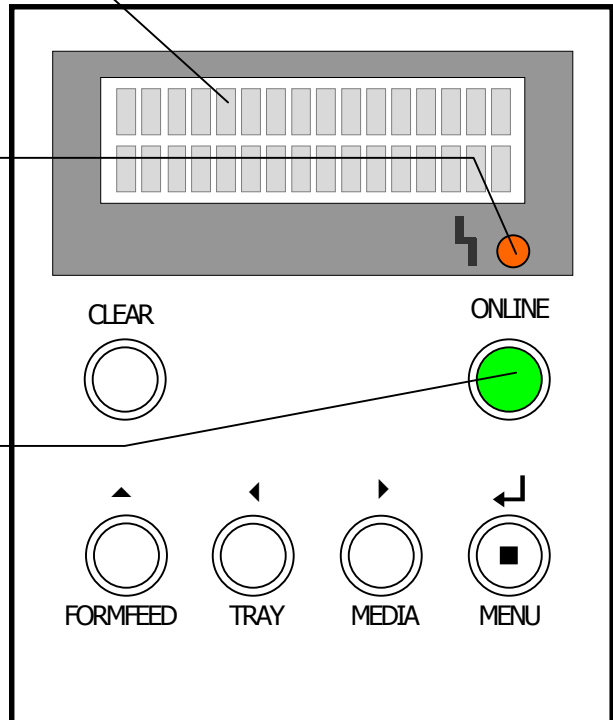

2. Messages

This section covers the messages displayed on the LCD.

2.1 LCD display

When the printer is up and running, the LCD shows messages relating to the state of the printer in the fixed format illustrated below.

When not printing

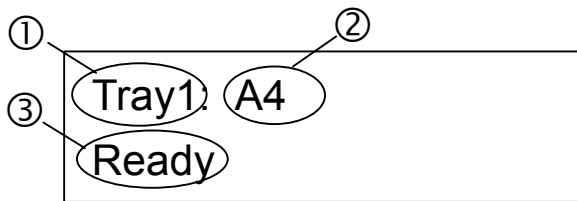

① Input tray specified

- “Tray1”: Tray 1
- “Tray2”: Tray 2

③ Condition of the printer

- “Ready”: The printer is ready for receiving, or in the middle of receiving, print data (online status).
- “Not ready”: The printer is not ready for receiving print data (offline status). Then, if no key operation is performed on the control panel for 30 seconds, the printer automatically enters the online status.

② Size of print media in the corresponding paper tray.

- “A4”: A4
- “A5”: A5
- “B5”: B5 (ISO) or B5 (JIS)
- “Exe.”: Executive
- “Legal”: Legal (with optional paper tray)
- “Letter”: Letter
- “HalfLTR.”: Half Letter
- “#10/DL”: Commercial #10 or International DL
- “FreeSize”: Configured size by user
(This is indicated when the printer is processing the free size data.)
- “---”: Undefined
- “NO” : No paper tray (removed)

When printing

Normally, the printer status is displayed in the lower line while receiving print data.

The display contents can be switched by pressing ▲ key to show the numbers of pages, the print mode, and user-defined information for the “Display at Paper Changing” function. See the printer driver help for further information.

Tray1: A4 Printing

This display shows the printer status.

Tray1: A4 (12P)

This display shows the numbers of printed pages.

Tray1: A4 Plain Mode

This display shows the print mode.

Tray1: A4 [ABCD] Printing

This display shows user-defined information for the “Display at Paper Changing” function. See the printer driver help for further information.

2.2 Messages

When the printer is powering up or when the printer requires the operator's response, the LCD shows messages showing the progress of powering-up or required actions in a free format. Follow the actions if suggested in the message.

■ Printer Condition messages

Ready	[State] The printer is ready for receiving, or in the middle of receiving, print data. [Action] No action. You can print.
Not ready	[State] The printer is not ready for receiving print data. [Action] Press ONLINE key or wait for 30 seconds.
Reset	[State] The printer is resetting. [Action] Wait for a while.
Cancel Job	[State] The printer is cancelling the print job. [Action] Wait for a while.
Printing	[State] The printer is printing. [Action] Wait for a while.
Toner Sensing	[State] The printer is calibrating. [Action] Wait for a while.
Test xx	[State] Initial test is running. [Action] Wait for a while.
Test finished	[State] Initial test is finished. [Action] Wait for a while.
Decompressing	[State] The printer firmware is decompressing. [Action] Wait for a while.

■ Warning messages (ERROR lamp is not light)

Warming Up	[State] The printer is warming up. [Action] Wait for a while. When the ONLINE lamp is lit, the printer can receive print data even during the warming-up process.
Check Toner xxxx	[State] The toner of color "x"—K (black), Y (yellow), M (magenta), or C (cyan), maybe up to four toners KYMC—will soon be exhausted. The remaining toner can print only 20 to 500 images, depending on the coverage of the toner color. [Action] Prepare a toner cartridge for the color. If you find spotted or drastically light print results, replace the toner cartridge at once. (See "2. Replacing the Toner Cartridge" in Chapter 2 on this manual.)

Replace WT. Pack	<p>[State] The waste toner pack will soon be exhausted.</p> <p>[Action] Prepare a waste toner pack. You still can print about 200 images (50 pages in colors) before the ERROR lamp turns on, but thereafter you cannot print any more data. The soonest action is recommended when this message appears. (See “4. Replacing the Waste Toner Pack” in Chapter 2 on this manual.)</p>
Replace Belt CG	<p>[State] The belt cartridge has been worn out.</p> <p>[Action] Replace the belt cartridge. (See “3. Replacing the Belt Cartridge” in Chapter 2 on this manual.)</p>
Replace Fuser	<p>[State] The fuser unit has been worn out.</p> <p>[Action] Ask your dealer or service representative to replace the fuser unit.</p>
Replace Parts xxx	<p>[State] The periodical replacement part “xxx” excluding the fuser unit has reached the replacement time.</p> <p>[Action] Ask your dealer or service representative to replace this part.</p>
Check Output Tray	<p>[State] The output tray will soon be full.</p> <p>[Action] Take out the printed media from the output tray.</p>
Sleep Mode	<p>[State] The printer is running in sleep mode (power save mode).</p> <p>[Action] No action. If the printer receives print data or if you press any key on the control panel, the printer returns to normal mode. You can choose whether this mode is used or not by setting the sleep mode. You can change the amount of time before the printer enters sleep mode by setting the sleep time. (See “4. Config Menu” in Chapter 5 on this manual.)</p>
Calibrating	<p>[State] The printer is calibrating.</p> <p>[Action] Wait for a while.</p>
TMA Sensor Error	<p>[State] A printer calibrating error has been detected.</p> <p>[Action] Turn off the printer, draw out the tray 1 from the printer, re-mount the paper tray and turn on the printer again. If this message appears often, contact your dealer or service representative. This error is displayed only when calibration mode is chosen as ON. If you do not notice any problem in the print result, you can choose whether calibration mode is used or not by setting the calibration mode. (See “4. Config Menu” in Chapter 5 on this manual.)</p>

■ Operator Call messages (with ERROR lamp is light)

Close Front Cover	[State] The front cover is open. [Action] Close the front cover.
Close Top Cover	[State] The top cover is open. [Action] Close the top cover.
Close Back Cover	[State] The back cover is open. [Action] Close the back cover.
Replace Toner x	[State] The toner of color “x”—K (black), Y (yellow), M (magenta), or C (cyan)—has been exhausted. [Action] Replace the toner cartridge for the color. (See “2. Replacing the Toner Cartridge” in Chapter 2 on this manual.)
Replace WT. Pack	[State] The waste toner pack has been filled with waste toner or the waste toner pack is not set. [Action] Replace or set the waste toner pack. (See “4. Replacing the Waste Toner Pack” in Chapter 2 on this manual.)
Set x Toner CG	[State] The toner cartridge for color “x”—K (black), Y (yellow), M (magenta), or C (cyan)—is not set. [Action] Set the toner cartridge for the color. (See “6. Preparing the printer” in Chapter 2 on Setup Guide.)
Set Belt CG	[State] The belt cartridge is not set. [Action] Set the belt cartridge. (See “6. Preparing the printer” in Chapter 2 on Setup Guide.)
Set Trayx	[State] The paper tray “x” is not set. [Action] Set the appropriate paper tray.
Trayx Load yyyy	[State] The paper tray “x” does not contain media, or does not contain the size “yyyy” of media to receive print data. [Action] Supply the specified size of media to the indicated paper tray (See “2. Loading Paper Trays with Print Media” in Chapter 1 on this manual.). You can also restart printing by changing the source paper tray using TRAY key (page 4-12).
Trayx Load zzzz	[State] Print data cannot be printed because tray “x” does not contain the media type “zzzz.” [Action] Replace the media in the indicated tray with the specified type of media (See “2. Loading Paper Trays with Print Media” in Chapter 1 on this manual.). If you do not have the specified type of media, you can print data by changing the media type using MEDIA key (page 4-13).
Check Front Cover	[State] The front cover is not firmly closed. [Action] Open the front cover, then firmly close it until it locks.

Toner CG Error	[State] An incorrect toner cartridge is set.
	[Action] Use a correct toner cartridge for the printer.
Output Tray Full	[State] The output tray has been full of printed media.
	[Action] Take out the printed media from the output tray.
Close DuplexUnit	[State] The duplex unit cover is open.
	[Action] Close the duplex unit cover. When this message remains even if the duplex unit cover is closed, check whether any other cover is opened or not.
JAM-A Tray, Rear	[State] A-E jam has occurred. [Action] Remove the media causing the jam. (See “1. Media Jams” in Chapter 6 on this manual.)
JAM-B Rear	
JAM-C Rear	
JAM-D Duplex	
JAM-E Duplex	
Open Front Cover	[State] Any event requiring the front cover to open has occurred.
	[Action] Open the front cover, then firmly close it until it locks.
Set Fuser Unit	[State] No fuser unit is set.
	[Action] Contact your dealer or service representative.
Set Transfer Roll	[State] No transfer roller is set.
	[Action] Contact your dealer or service representative.
Data Error	[State] The printer has received invalid print data.
	[Action] Press the CLEAR key to erase the print data (page 4-11). If this message appears often, contact your dealer or service representative.

■ Service Call messages

SVC xxx ERROR	[State] A printer error has been detected.
	[Action] Turn off the printer, wait five seconds or more, and turn on the printer again. If this message appears often, contact your dealer or service representative.
Error Recovery	

■ Other messages

Please Wait	[State] Initial diagnostics is running.
	[Action] Wait for a while.
Init EEPROM	[State] Initial diagnostics is running.
	[Action] Wait for a while.
Executing	[State] printer is executing the action.
	[Action] Wait for a while.

Completed	[State] printer completed the action.
	[Action] Wait for a while.
Firmware Update	[State] Printer firmware is updating.
	[Action] Wait for a while.
Downloading	[State] Printer is receiving the firmware.
	[Action] Wait for a while.
Time Out Error	<div style="display: flex; align-items: center;"> <div style="font-size: 3em; margin-right: 5px;">}</div> <div> <p>[State] An error occurred while the printer firmware is downloading.</p> <p>[Action] Push any key to start previous firmware and retry firmware download.</p> </div> </div>
Format Error	
Check Sum Error	
Connection Error	
and	
Push Any Key	
Change Tray x: yyyy (zzzz): aaaa	<p>[State] The printer is temporarily stopped, requesting a manual intervention to continue the print job for tray “x,” media size “yyyy,” and media type “zzzz” from the user “aaaa.” This has been caused by the “Display at Paper Changing” function of the printer driver (See “3. Setting the Printer Driver” in Chapter 1 on this manual and the printer driver help for further information.).</p> <p>[Action] See if the corresponding paper tray is loaded with applicable media. If you are sure without removing the tray, press any key on the control panel other than ONLINE and CLEAR, and the printer starts printing. If you are not, remove the paper tray, confirm the contents and, if necessary, replace the contents with the specified media. Then, insert the tray again, and the printer starts printing.</p>
PM Error	<p>[State] A page memory error occurred.</p> <p>[Action] The error is temporary. If you do not notice any problem in the print result, keep using the printer as it is. If this message appears often, contact your dealer or service representative.</p>

■ Media size indication (yyyy)

Indication	Media size	Indication	Media size
A4	A4	LTR.	Letter
A5	A5	HLT.	Half Letter
B5	B5 (ISO) or B5 (JIS)	#10	Commercial #10
EXE.	Executive	DL	International DL
LGL.	Legal	Free	User-defined

■ Printr media indication (zzzz)

Indication	Media type	Indication	Media type
Thin	Plain paper	Label	Label Sheet
Plain	Plain paper	Env1	Envelope
MThic	Thick paper	Env2	Thick Envelope
Thic1	Thick paper	Trans	Transparency (OHP film)
Thic2	Thick paper	Spec.	Special paper

3. Functions of Control Keys

The control panel has six control keys that operate in two different modes: normal mode and panel menu mode.

- In normal mode:
 - CLEAR, FORMFEED, ONLINE, TRAY and MEDIA keys are effective.
- In panel menu mode, activated with MENU key, ◀, ▶, and ▲ keys are effective for setting the environment of the printer.

This section explains the major functions of control keys in normal mode. For the control key functions in panel menu mode, see Chapter 5 on this manual.

Functions of the control keys effective in normal mode are shown below.

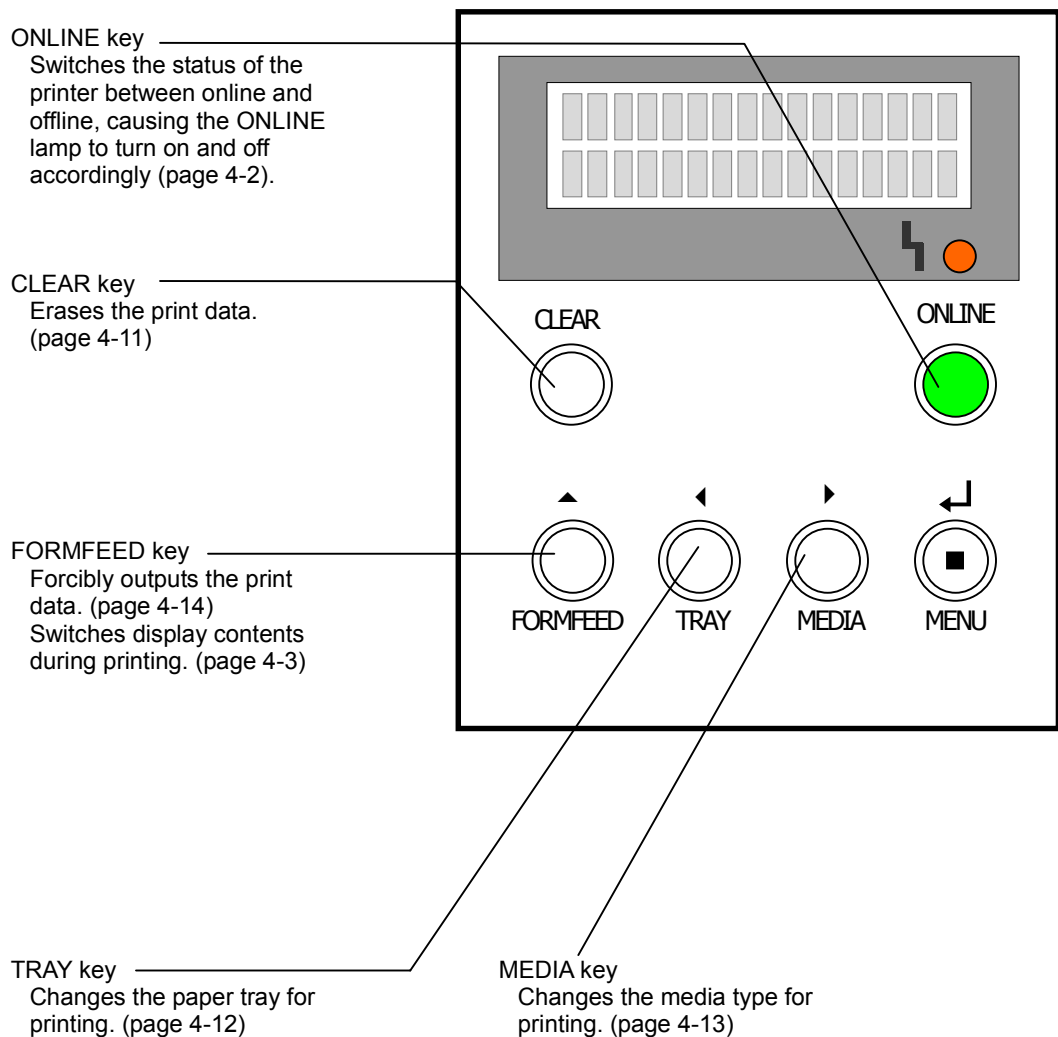

3.1 CLEAR Key (Erasing Print Data)

There are two ways of canceling the print data with CLEAR key: job clear and data reset as shown in the table below. The procedure for erasing the print job using CLEAR key follows.

<p>Job Clear Press CLEAR key quickly.</p>	<p>Cancels the print job which has been received first. If receiving the first print job is in progress, it will be cleared after the completion of the process, so that it may take much time to clear a huge print job.</p>
<p>Data Reset Hold down CLEAR key for two seconds or more.</p>	<p>Cancels all of the print jobs which have been received, but the print job in receiving process remains. Consequently, it is necessary to delete the print job on the PC.</p>

Operating procedure

- (a) Check the LCD display to see if it is printing.

If the LCD display shows not printing, the printer has not received any of the print data. You can stop printing by deleting the print job on the PC.

- (b) If the LCD display shows printing, press ONLINE key to cause the printer to stop receiving the print data (offline status in which the ONLINE lamp is off).

If you are to perform a data reset, delete the target print job on the PC before you proceed to step (c).

- (c) Press or hold down CLEAR key.

- Job clear: Press CLEAR key and release it quickly. The resulting action may take long time.
 - To cancel an ongoing job clear, repeat step (b) and then perform data reset.
 - A job clear may not result if the ERROR lamp is lit. First take necessary actions in accordance with the message contents, and then perform a job clear.
- Data reset: Hold down CLEAR key for three seconds or more.

Tray1: A4
Cancel Job

Tray1: A4
Reset

3.2 TRAY Key (Changing the Paper Tray for Printing)

You can change the paper tray to the other one containing the print media in an applicable size, according to the procedure below.

Operating procedure

- (a) Ensure that the message requesting change of the media in a different size is displayed.
- (b) Press TRAY key to change the paper tray.
- (c) Press ONLINE key.

Tray1: A4
Tray1 Load B5

Tray1: A4
Tray2 Load B5

The print media is fed from the paper tray indicated in the upper row of the display.

Tray2: B5
Printing

- Pressing FORMFEED key instead of ONLINE invalidates the setting with TRAY key, and forces the output of the print data. (page 4-14)
- If the media size or type after the change is unavailable for Tray 2, the media must be fed from the originally selected Tray 1 and, therefore, you cannot change trays to print data.

3.3 MEDIA Key (Changing the Media Type for Printing)

If you do not have the media type specified in the message, use this key to change the media type. The procedure is as shown below.

Operating procedure

- (a) Ensure that the message requesting change of the media of a different type is displayed.

```
Tray1: A4
Tray1 Load Trans
```

- (b) Press MEDIA key to select the type of media contained in the corresponding paper tray.

```
Tray1: A4
Tray1 Load Plain
```

- (c) Press ONLINE key.

```
Tray1: A4
Printing |
```

The media of the existing type is fed from the corresponding paper tray to print data.

- **Pressing FORMFEED key instead of ONLINE invalidates the setting with MEDIA key, and forces the output of the print data. The media type is set to “Trans” only when the target tray is Tray 1 and transparencies are contained in that tray. In other cases, the media type is set to “Plain” for the forced output of the print data. (page 4-14)**
- **Printing on the type of media different from the one defined for the print job may cause incorrect print results, e.g., dislocated print or partially missing print. The latter instance stains the inside of the printer with the toner for the missing part, thus leading to a hardware failure.**

3.4 FORMFEED Key (Forcibly Outputting Print Data)

You can forcibly output the print data by either of the following methods.

3.4.1 Forcing Output of Print Data without Changing Media or Paper Tray

Operating procedure

- (a) Ensure that the message requesting change of the media in a different size or of a different type is displayed. Both samples are shown below.

Tray1: A4 Tray1 Load LTR.

Tray1: A4 Tray1 Load Trans

- (b) Press FORMFEED key, and the print data will be forcibly output onto the media fed from the paper tray shown in the upper line of the LCD.

Tray1: A4 Printing

- **Pressing FORMFEED key to print data invalidates the media type defined for the print job. The media type is set to “Trans” only when the target tray is Tray1 and transparencies are contained in that tray. In other cases, the media type is set to “Plain” for the forced output of the print data.**
- **Printing on the type of media different from the one defined for the print job may cause incorrect print results, e.g., dislocated print or partially missing print. The latter instance stains the inside of the printer with the toner for the missing part, thus leading to a hardware failure.**

Chapter 5 Panel Menu Functions

- 1. Panel Menu Overview -----5-2**
- 2. Operating Panel Menus-----5-4**
- 3. Test Menu -----5-6**
- 4. Config Menu----- 5-14**

1. Panel Menu Overview

The printer has menus to be set on the control panel according to your printing environment. Such menus are collectively called “panel menus.” The table below lists the panel menus and their functions. The subsequent figure shows the hierarchical structure of these menus and functions when displayed on the control panel LCD (“*” = factory-set default).

Menu	Function
Test Menu (page 5-6)	Prints the test pattern (Test Page), prints the printer’s configuration information (Config Page), prints the printer’s status information (Status Page), and specifies the printing conditions for these pages (plain paper, transparency, thick paper, duplex print, etc...).
Config Menu (page 5-14)	Specifies the printer configuration settings: timeout condition, sleep mode, sleep time, port selection mode, auto mode port selection priority, display language, display paper size for installing small size paper, paper tray priority, and calibration mode.

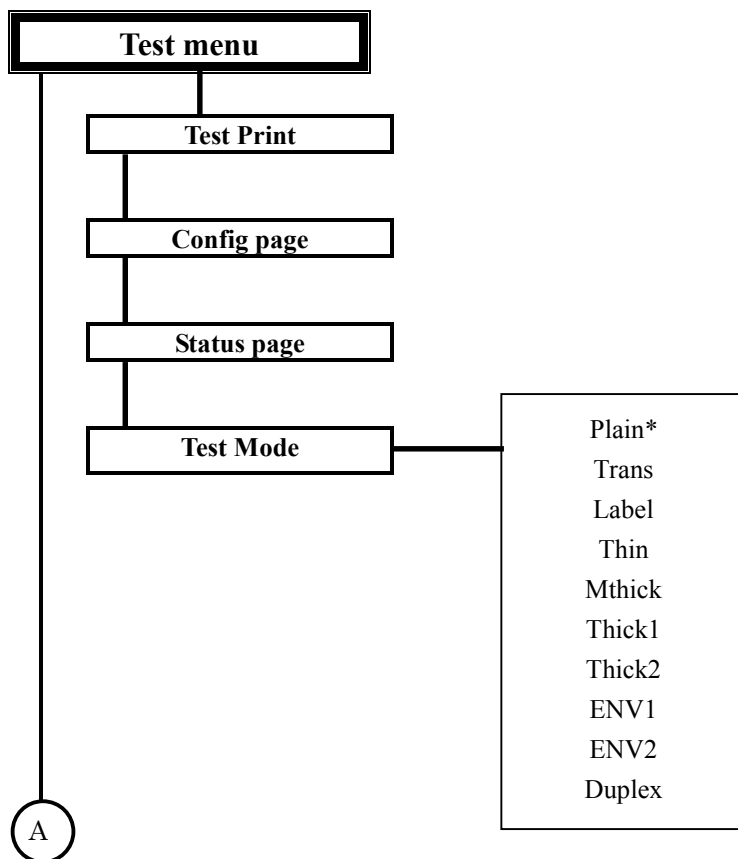

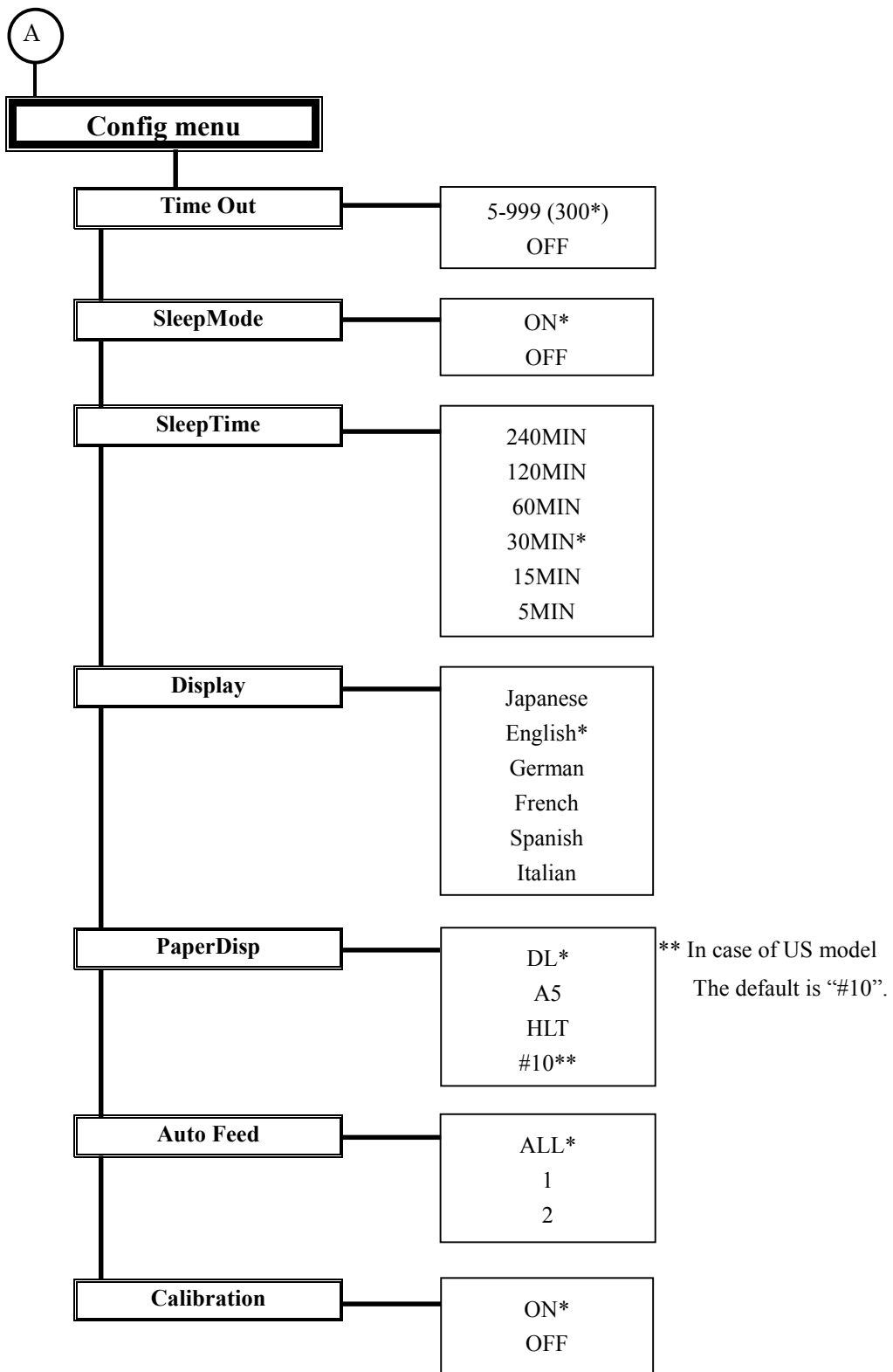

2. Operating Panel Menus

Of the six control keys on the control panel, MENU/ENTER, ◀, ▶, and ▲ keys are effective for setting the environment of the printer in panel menu mode. In addition, ONLINE key is used to offline the printer prior to entering panel menu mode, or forcibly terminate panel menu mode.

Functions of the control keys on the control panel relating to panel menu operation are shown below. Be noted that this illustration only applies to panel menu mode. For explanation of the control panel key in normal mode, see Chapter 4.

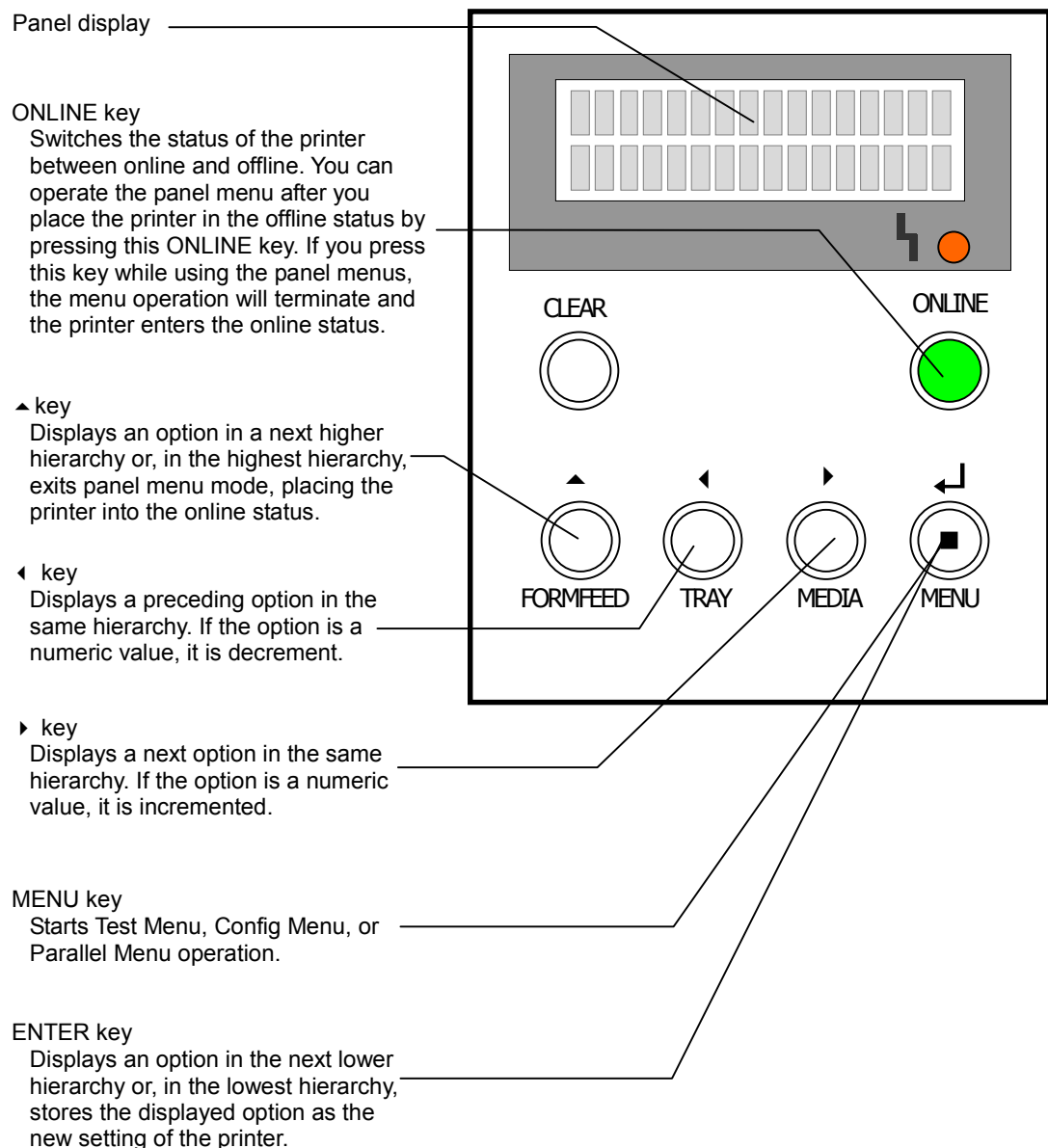

Display Format in Panel Menu Mode

The menu display appears in the second line of the LCD as shown below.

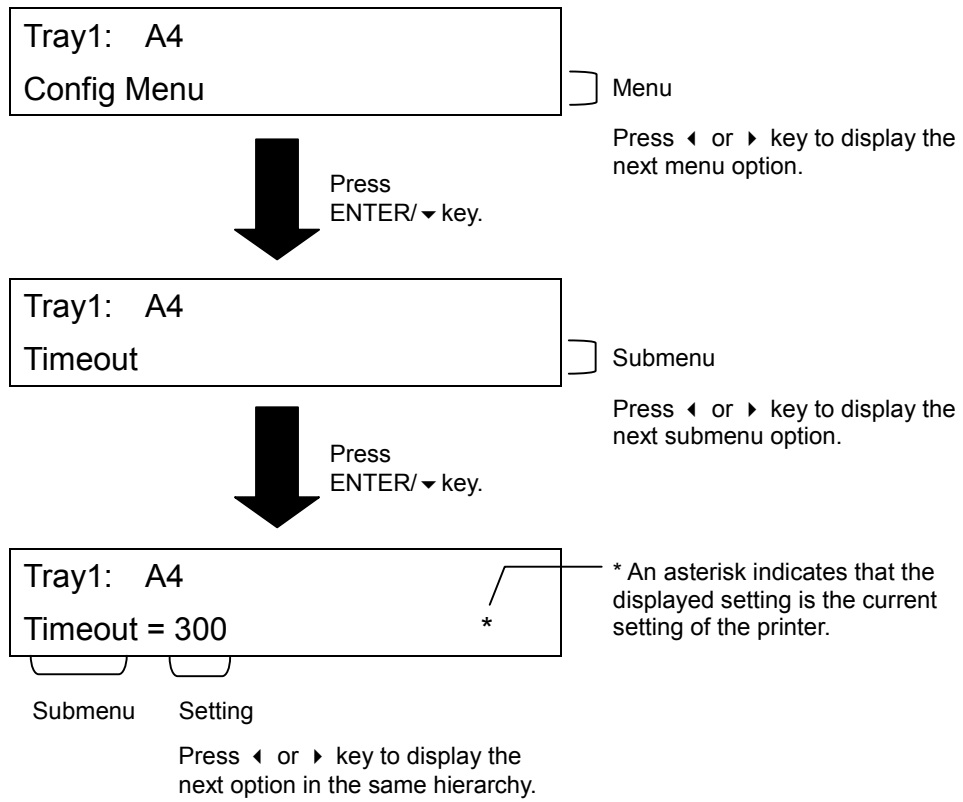

3. Test Menu

3.1 Starting Test Menu

You can start Test Menu operation according to the procedure below.

Procedure for starting Test Menu operation

(a) Ensure that "Ready" is displayed on the LCD.	Tray2: B5 Ready
(b) Press ONLINE key. The ONLINE lamp goes out when the printer enters offline mode.	Tray2: B5 Not Ready
(c) Press TRAY key to select the input tray for printing with Test Menu.	Tray1: A4 Not Ready
(d) Press MENU key, and Test Menu is activated.	Tray1: A4 Test Menu

3.2 Test Page Print (TestPrint Submenu)

This submenu prints the test pattern (Test Page) on the printer under the following conditions:

- Input tray: The input tray displayed in the upper line of the LCD takes precedence. If the media type setting is transparency, Tray 1 will be selected.
- Media size: Although the Test Page fits A4 size, the media in the selected input tray automatically applies to printing. If the media size is smaller than A4, the test page will be partially printed.
- Media type and print mode (simplex or duplex): These settings are determined by TestMode submenu (page 5-12).

Shown below is the procedure for printing the Test Page when Test Menu has been selected. A sample printout follows the procedure.

Procedure for printing the Test Page

(a) Ensure that Test Menu has been activated.
(page 5-6)

Tray1: A4
Test Menu

(b) Press ENTER key. Test Print submenu appears.

Tray1: A4
TestPrint

(c) Press ENTER key to start printing. The display begins to blink when printing starts. When printing terminates, the printer enters offline mode.

Tray1: A4
TestPrint



Tray1: A4
Not Ready

(d) Press ONLINE key to terminate the menu operation and cause the printer to enter online mode.

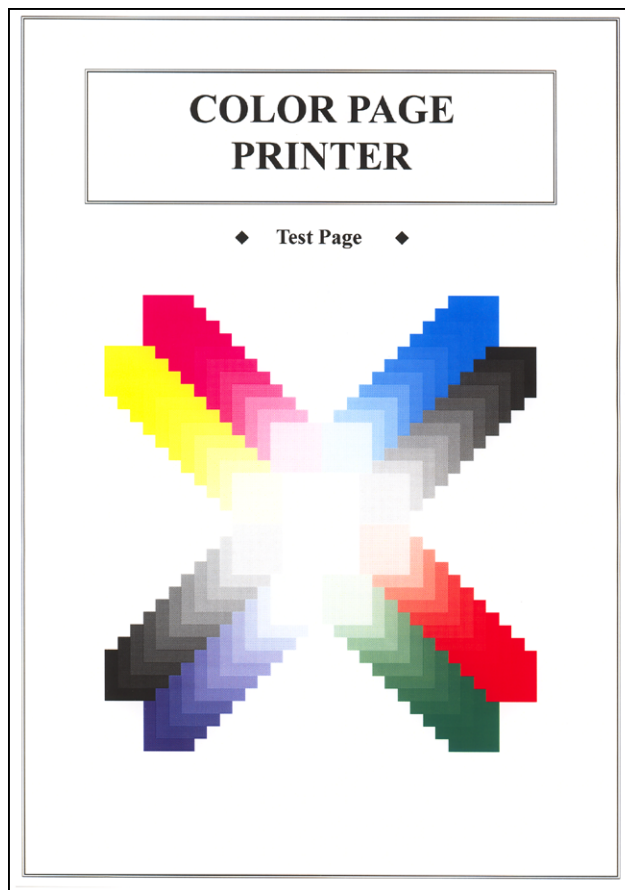

The actual printout differs from the above example in color and size.

3.3 Config Page Print (ConfigPage Submenu)

This submenu prints the printer's configuration information (Config Page) as shown on next page, under the following conditions:

- Input tray: The input tray displayed in the upper line of the LCD takes precedence. If the media type setting is transparency, Tray 1 will be selected.
- Media size: The Config Page fits A4 or Letter size. If the input tray contains media in a different size, printing is halted. In such a case, you can continue printing after you replace the media in that tray with those in A4 or Letter size.
- Media type: This setting is determined by TestMode submenu (page 5-12).

Shown below is the procedure for printing the Config Page when Test Menu has been selected. A sample printout follows the procedure.

Procedure for printing the Config Page

- (a) Ensure that Test Menu has been activated.
(page 5-6)

Tray1: A4
Test Menu

- (b) Press ENTER key. Test Print submenu appears.

Tray1: A4
TestPrint

- (c) Press ◀ or ▶ key to select Config Page submenu.

Tray1: A4
ConfigPage

- (d) Press ENTER key to start printing. The display begins to blink when printing starts. When printing terminates, the printer enters offline mode.

Tray1: A4
ConfigPage



Tray1: A4
Not Ready

- (e) Press ONLINE key to terminate the menu operation and cause the printer to enter online mode.

COLOR PAGE PRINTER

◆ Configuration Page ◆

● Printer Information

Page count :7661
Total image count :25496
Total memory size :64MB

Paper feed tray 1 :A4

● Parts Life Information

Black toner :Normal
Yellow toner :Normal
Magenta toner :Normal
Cyan toner :Normal
Belt cartridge :Normal
Waste toner pack :Normal
Fuser unit :Normal
Periodical parts :Normal

● Software Information

Firmware version :00-02
MCTL version :SL5 V140
DPTL version :DL5 V070

● Panel Menu Information

TEST MENU SETTINGS
Test mode :Plain

CONFIG MENU SETTINGS
Job timeout :300s
Sleep mode :OFF
Sleep time :None
Display language :English
Paper display :#10
Toner calibration :ON

● Unit Information

Paper feeder unit :None
Duplex printing unit:Attached

The actual printout differs from the above example in size.

- Printer Information: Shows the total number of printed pages, the total number of images, the amount of printer memory, and the size of media in each input tray.
- Parts Life Information: Shows when to replace the consumables and periodical replacement parts.
- Software Information: Shows software versions of the printer.
- Panel Menu Information: Shows the panel menu settings.
- Unit Information: Shows installed options.

3.4 Status Page Print (Status Page Submenu)

This submenu prints the printer's status information (status Page) as shown on next page, under the following conditions:

- Input tray: The input tray displayed in the upper line of the LCD takes precedence. If the media type setting is transparency, Tray 1 will be selected.
- Media size: The Status Page fits A4 or Letter size. If the input tray contains media in a different size, printing is halted. In such a case, you can continue printing after you replace the media in that tray with those in A4 or Letter size.
- Media type: This setting is determined by TestMode submenu (page 5-12).

Shown below is the procedure for printing the Status Page when Test Menu has been selected. A sample printout follows the procedure.

Procedure for printing the Status Page

- (a) Ensure that Test Menu has been activated.
(page 5-6)

Tray1: A4
Test Menu

- (b) Press ENTER key. Test Print submenu appears.

Tray1: A4
TestPrint

- (c) Press ◀ or ▶ key to select Status Page submenu.

Tray1: A4
StatusPage

- (d) Press ENTER key to start printing. The display begins to blink when printing starts. When printing terminates, the printer enters offline mode.

Tray1: A4
StatusPage



Tray1: A4
Not Ready

- (e) Press ONLINE key to terminate the menu operation and cause the printer to enter online mode.

COLOR PAGE PRINTER

◆ Status Page ◆

● Total Image Information

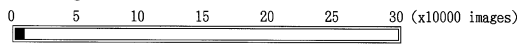

● Parts Life Information

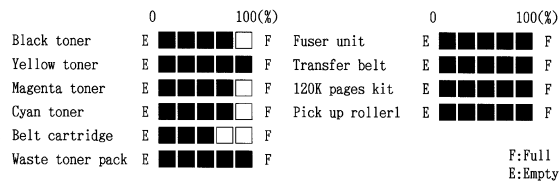

● Printing Information

Paper size	Duplex		Simplex	
	Color	Monochrome	Color	Monochrome
Legal	0	0	0	0
A4 Letter	436	0	2815	607
B5 Executive	0	0	0	0
Other	0	0	0	0

● Calibration Information

Latest Calibration : -

The actual printout differs from the above example in size.

- Total Image Information: Shows the roughly printed total image number.
- Parts Life Information: Shows the roughly consumable's and replacement part's life.
- Printing Information: Shows the printed total page number.
- Calibration Information: Shows the latest calibration information.

3.5 Printer Setup for Test Print (TestMode Submenu)

This submenu specifies the media type and print mode for printing TestPage, Config Page, and status Page. The options selectable for the printer's setting are shown below. Following this table is the procedure for setting up the printing conditions for Test Page, Config Page, and status Page when Test Menu has been activated.

If you specify a setting option other than TRANS, the specified media type applies to printing regardless of the actual type of media in the selected input tray. Be sure to select an applicable setting option in this submenu.

Option	Description
PLAIN*	Specifies simplex print on plain paper (75g/m ² to 89g/m ²).
TRANS	Specifies simplex print on OHP film (transparency). Printing with this option stops until the media in tray 1 is replaced with an OHP film (transparency).
LABEL	Specifies simplex print on label.
THIN	Specifies simplex print on plain paper (60g/m ² to 74g/m ²).
MTHICK	Specifies simplex print on thick paper (90g/m ² to 104g/m ²).
THICK1	Specifies simplex print on thick paper (105g/m ² to 163g/m ²).
THICK2	Specifies simplex print on thick paper (164g/m ² to 210g/m ²).
ENV1	Specifies simplex print on envelope.
ENV2	Specifies simplex print on envelope.
DUPLEX	Specifies duplex print on plain paper. This option takes effect only when the Duplex Unit option is installed and Test Page is to be printed.

(*: default)

It is necessary to set up a paper kind with the thickness of a paper. Although thickness of the table serves as a standard of a setup, the printer may need to be changed a setup by quality of paper etc...

Procedure for setting up the printer for Test Print

- (a) Ensure that Test Menu has been activated.
(page 5-6)

Tray1: A4
Test Menu
- (b) Press ENTER key. TestPrint submenu appears.

Tray1: A4
TestPrint
- (c) Press ◀ or ▶ key to select TestMode submenu.

Tray1: A4
TestMode
- (d) Press ENTER/▼ key, and the current setting appears with an asterisk.

Tray1: A4
TestMode=PLAIN *
- (e) Press ◀ or ▶ key proper times until the target setting option appears.

Tray1: A4
TestMode=TRANS
- (f) Press ENTER/▼ key to save the selected option as the new setting for the printer, suffixed with an asterisk.

Tray1: A4
TestMode=TRANS *
- (g) Press ONLINE key to terminate the menu operation and cause the printer to enter online mode.

4. Config Menu

4.1 Starting Config Menu Operation

You can start Config Menu operation according to the procedure below.

Procedure for starting Config Menu operation

(a) Ensure that “Ready” is displayed on the LCD.

**Tray1: A4
Ready**

(b) Press ONLINE key. The ONLINE lamp goes out when the printer enters offline mode.

**Tray1: A4
Not Ready**

(c) Press MENU key, and Test Menu is activated.

**Tray1: A4
Test Menu**

(d) Press ◀ or ▶ key to select Config Menu.

**Tray1: A4
Config Menu**

4.2 Timeout Condition (Timeout Submenu)

This submenu specifies the printer's action when the printer's reception of print data is suspended. The options for this submenu selectable for the printer's setting are shown below. Following this table is the procedure for setting the timeout condition when Config Menu has been selected.

Option	Description
5 to 999 (300*)	Specifies the amount of time in seconds to cause timeout when the printer's reception of print data is suspended. When the specified time has passed since the suspended reception of print data, the printer forcibly outputs the partially received data to receive new print data. The result may be a printout with partial loss of data, an incorrect printout, or no printout.
OFF	Specifies no timeout. The printer waits for the remaining print data.

(*: default)

Procedure for setting the timeout condition

- (a) Ensure that Config Menu has been selected.
(page 5-14)

Tray1: A4
Config Menu

- (b) Press ENTER key. Timeout submenu appears.

Tray1: A4
Timeout

- (c) Press ENTER key, and the current setting appears with an asterisk.

Tray1: A4
Timeout = 300 *

- (d) Press ◀ or ▶ key proper times, or hold down the key, until the target setting option appears.

Tray1: A4
Timeout = 600

- (e) Press ENTER key to save the selected option as the new setting for the printer, suffixed with an asterisk.

Tray1: A4
Timeout = 600 *

- (f) Press ONLINE key to terminate the menu operation and cause the printer to enter online mode.

4.3 Sleep Mode (Sleep Mode Submenu)

This submenu specifies the printer's action to use or not use the sleep mode (minimum power consumption mode).

Option	Description
ON*	The printer enters sleep mode to save the power consumption when the specified time (page 5-17) has passed since the printer's receiving the last print job.
OFF	The printer don't enter sleep mode to save the power consumption.

(*: default)

Procedure for setting the sleep mode

- (a) Ensure that Config Menu has been selected.
(page 5-14)

Tray1: A4
Config Menu

- (b) Press ENTER key. Timeout submenu appears.

Tray1: A4
Timeout

- (c) Press ◀ or ▶ key to select SleepTime submenu.

Tray1: A4
SleepMode

- (d) Press ENTER key, and the current setting appears with an asterisk.

Tray1: A4
SleepMode = ON *

- (e) Press ◀ or ▶ key to select the target setting option.

Tray1: A4
SleepMode = OFF

- (f) Press ENTER key to save the selected option as the new setting for the printer, suffixed with an asterisk.

Tray1: A4
SleepMode = OFF *

- (g) Press ONLINE key to terminate the menu operation and cause the printer to enter online mode.

4.4 Sleep Time (SleepTime Submenu)

This submenu specifies the amount of time in minutes to precede the printer's entrance into sleep mode (minimum power consumption mode).

Option	Description
30M*, 60M, 120M, 240M, 5M, and 15M	Specifies the selected amount of time as the preceding time of sleep mode. When the specified time has passed since the printer's receiving the last print job, the printer enters sleep mode to save the power consumption.

(*: default)

Counting the preceding time of sleep mode resets when any key on the control panel is pressed or the ERROR lamp is lit. The printer enters sleep mode when the specified time has passed after the key operation is finished or the ERROR lamp is turned off. Conversely, the printer exits sleep mode when a print job is received or any key on the control panel is pressed.

Procedure for setting the sleep time

(a) Ensure that Config Menu has been selected. (page 5-14)

Tray1: A4
Config Menu

(b) Press ENTER key. Timeout submenu appears.

Tray1: A4
Timeout

(c) Press ◀ or ▶ key to select SleepTime submenu.

Tray1: A4
Sleeptime

(d) Press ENTER key, and the current setting appears with an asterisk.

Tray1: A4
Sleeptime = 30M *

(e) Press ◀ or ▶ key proper times, or hold down the key, until the target setting option appears.

Tray1: A4
Sleeptime = 15M

(f) Press ENTER key to save the selected option as the new setting for the printer, suffixed with an asterisk.

Tray1: A4
Sleeptime = 15M *

(g) Press ONLINE key to terminate the menu operation and cause the printer to enter online mode.

4.5 Display Language (Display Submenu)

This submenu specifies the language to be displayed on the control panel. The options for this submenu selectable for the printer's setting are shown below.

Option	Description
JAPANESE	Specifies display in Japanese.
ENGLISH*	Specifies display in English.
GERMAN	Specifies display in German.
FRENCH	Specifies display in French.
SPANISH	Specifies display in Spanish.
ITALIAN	Specifies display in Italian.

(*: default)

Procedure for setting Display Language

- (a) Ensure that Config Menu has been selected.
(page 5-14)

Tray1: A4
Config Menu

- (b) Press ENTER key. Timeout submenu appears.

Tray1: A4
Timeout

- (c) Press ◀ or ▶ key to select Display submenu.

Tray1: A4
Display

- (d) Press ENTER key, and the current setting appears with an asterisk.

Tray1: A4
Display = ENGLISH *

- (e) Press ◀ or ▶ key to select the target setting option.

Tray1: A4
Display = JAPANESE

- (f) Press ENTER key to save the selected option as the new setting for the printer, suffixed with an asterisk.

Tray1: A4
Display = JAPANESE *

- (g) Press ONLINE key to terminate the menu operation and cause the printer to enter online mode.

4.6 Paper Display (Paper Display Submenu)

This submenu specifies the paper size to be displayed on the control panel when the selected tray detect small size paper. The options for this submenu selectable for the printer's setting are shown below.

Option	Description
DL*	Specifies display DL.
A5	Specifies display A5
HLT	Specifies display HLT
A6	Specifies display A6
#10	Specifies display #10

(*: default)

Procedure for setting Paper Display

- (a) Ensure that Config Menu has been selected. (page 5-14)

Tray1: A4
Config Menu

- (b) Press ENTER key. Timeout submenu appears.

Tray1: A4
Timeout

- (c) Press ◀ or ▶ key to select Paper Disp submenu.

Tray1: A4
PaperDisp

- (d) Press ENTER key, and the current setting appears with an asterisk.

Tray1: A4
PaperDisp = DL *

- (e) Press ◀ or ▶ key to select the target setting option.

Tray1: A4
PaperDisp = A5

- (f) Press ENTER key to save the selected option as the new setting for the printer, suffixed with an asterisk.

Tray1: A4
PaperDisp = A5 *

- (g) Press ONLINE key to terminate the menu operation and cause the printer to enter online mode.

4.7 Auto Feed (Auto Feed Submenu)

This submenu specifies the paper tray to print when paper tray selection of a printer driver is automatic.. The options for this submenu selectable for the printer's setting are shown below.

Option	Description
ALL*	Specifies automatic priority. The printer select the tray installed the nearest size.
1	Specifies tray 1.
2	Specifies tray 2.

(*: default)

Procedure for setting Auto Feed

(a) Ensure that Config Menu has been selected. (page 5-14)

Tray1: A4
Config Menu

(b) Press ENTER key. Timeout submenu appears.

Tray1: A4
Timeout

(c) Press ◀ or ▶ key to select Auto Feed submenu.

Tray1: A4
Auto Feed

(d) Press ENTER key, and the current setting appears with an asterisk.

Tray1: A4
Auto Feed = ALL *

(e) Press ◀ or ▶ key proper times until the target setting option appears.

Tray1: A4
Auto Feed = 1

(f) Press ENTER key to save the selected option as the new setting for the printer, suffixed with an asterisk.

Tray1: A4
Auto Feed = 1 *

(g) Press ONLINE key to terminate the menu operation and cause the printer to enter online mode.

4.8 Calibration (Calibration Submenu)

This submenu specifies the toner calibration. The options for this submenu selectable for the printer's setting are shown below.

Option	Description
ON*	Specifies the printer use calibration.
OFF	Specifies the printer don't use calibration.

(*: default)

Procedure for Calibration

- (a) Ensure that Config Menu has been selected.
(page 5-14)

Tray1: A4
Config Menu

- (b) Press ENTER key. Timeout submenu appears.

Tray1: A4
Timeout

- (c) Press ◀ or ▶ key to select Calibration submenu.

Tray1: A4
Calinration

- (d) Press ENTER key, and the current setting appears with an asterisk.

Tray1: A4
Calinration = ON *

- (e) Press ◀ or ▶ key proper times until the target setting option appears.

Tray1: A4
Calinration = OFF

- (f) Press ENTER key to save the selected option as the new setting for the printer, suffixed with an asterisk.

Tray1: A4
Calinration = OFF *

- (g) Press ONLINE key to terminate the menu operation and cause the printer to enter online mode.

Chapter 6 Troubleshooting

- 1. Media Jams -----6-2**
- 2. Actions on Print Quality Problems ----- 6-16**
- 3. Actions on Incorrect Print Results ----- 6-18**
- 4. Actions on Abnormal Printer Operation ----- 6-20**

1. Media Jams

CAUTION

When removing misfed paper, do not touch the fuser unit because it could be very hot.

If a media jam occurs in the printer, the LCD message in the control panel displays the location of the jam. Take actions according to the message.

Notes on media removal

- You can resolve the media jam only by carefully drawing out the media in accordance with the correct procedure. Do not attempt to forcibly remove the media, which may cause failure of the printer.
- There may be two or more sheets of media that cause the jam. Remove all the sheets.
- Check that the removed media is not torn. If it is torn, fragments may be left in the printer. Remove all the media fragments as well.
- Before removing all the media causing the jam, do not attempt to close the cover or turn off and on the printer. Otherwise, the remaining media may move within the printer, making it difficult to resolve the jam.

1.1 Media Jam Locations

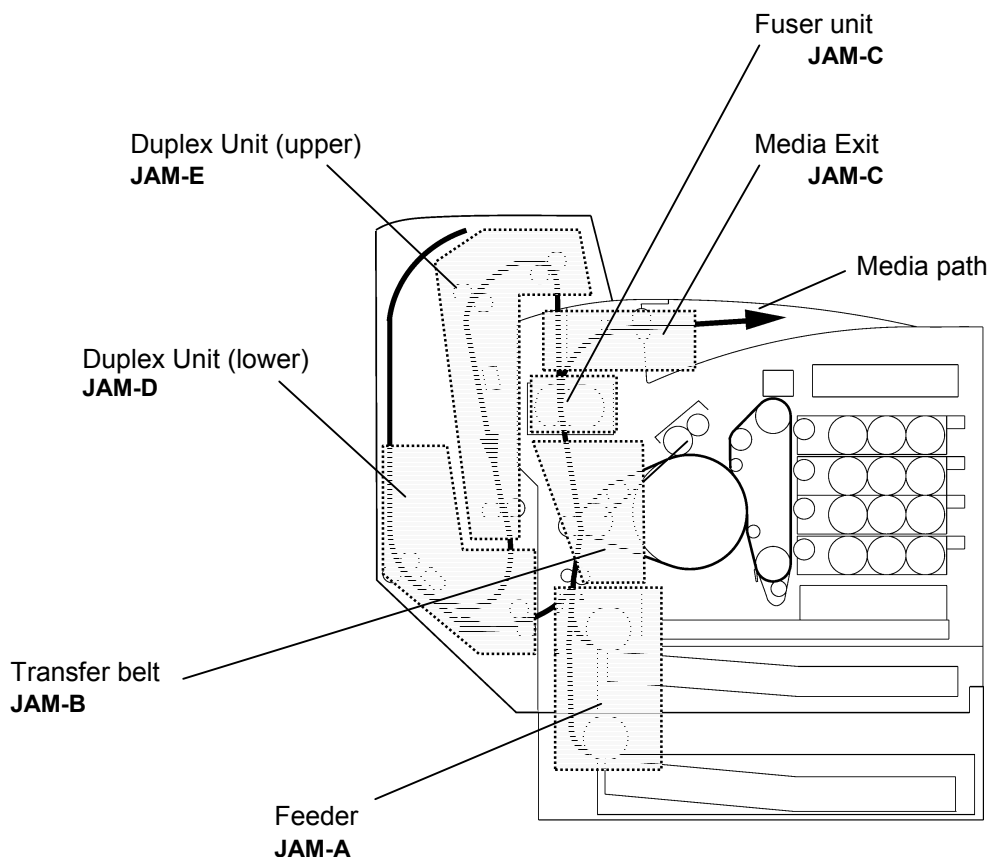

1.2 Determining Media Jam Locations by LCD Messages

When media jam has occurred, the LCD on the control panel shows a message in the format below. Determine the locations of the jam according to the message.

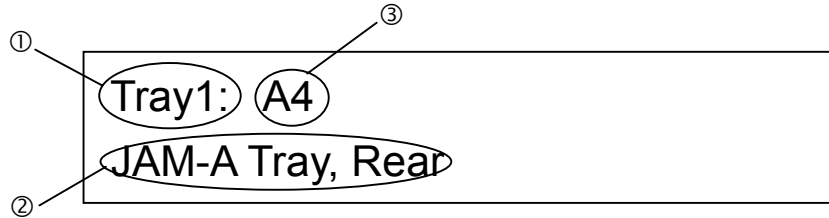

- ① Input tray selected
 - ② Size of the media in the corresponding paper tray
 - ③ Location of the jam, and parts (tray and/or cover) to be removed and/or opened for resolving the jam
-
- “JAM-A Tray, Rear”: A media jam has occurred between the feeder and the transfer drum. To resolve the jam, remove the paper tray and open the back cover of the printer.
 - “JAM-B Rear”: A media jam has occurred near the transfer belt. To resolve the jam, open the back cover of the printer.
 - “JAM-C Rear”: A media jam has occurred between the transfer belt and the fuser unit. To resolve the jam, open the back cover of the printer.
 - “JAM-D Duplex”: A media jam has occurred in the lower part of Duplex Unit. To resolve the jam, open the back cover and the duplex cover.
 - “JAM-E Duplex”: A media jam has occurred in the upper part of Duplex Unit. To resolve the jam, open the back cover, the duplex cover and inner paper guide.

1.3 Removing Jams from the Printer

Important

- Toner dust may be on the misfed paper after removal. Be careful not to get it on your hands or clothes.
- Toner dust may be on the paper printed after removing misfed paper. Make a few prints until smears do not appear any more.
- Forcefully removing misfed paper may cause paper to tear and leave scraps of paper in the printer. This might cause a misfeed and damage the printer.

1.3.1 Removal Procedure for JAM-A

Remove the jammed media according to the procedure below.

The procedure for resolving JAM-A instructs you, after letting you remove one sheet of media, to search for more media in accordance with the subsequent steps. There may be cases when a few sheets of media remain inside the printer.

Removal procedure for JAM-A

CAUTION

When pulling the paper tray out, be careful not to pull it strongly. If you do, the tray might fall and cause an injury.

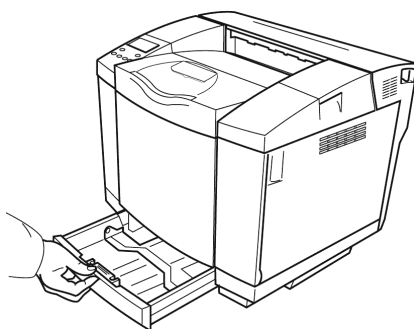

- (a) Determine the target paper tray from the LCD message. Then, remove the paper tray.

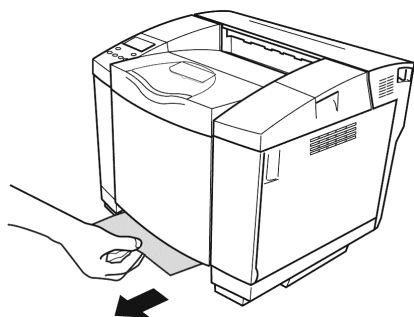

- (b) Carefully pull the jammed media toward yourself.
- **Do not forcibly pull the media when it is not likely to come out.**
 - **Look into the holder for the paper tray, and visually check out to see if any media or its fragments are left.**

- **A sheet may have jammed in the rear. If you cannot find the jammed sheet, try searching at the very back. OHP sheets are especially hard to find.**

If you succeed in pulling out the media, go to step (c). If not, remove the media from the rear of the printer in accordance with removal procedure for JAM-B. (page 6-6)

- (c) Make sure that the four corners of the media are set firmly in the paper tray. Then, put back the paper tray.

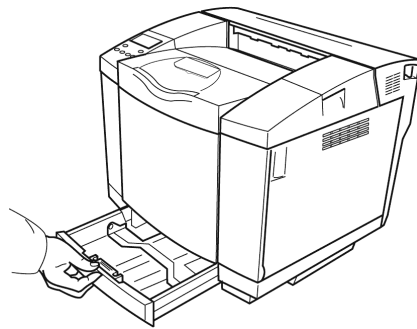



If JAM-A occurs often

If JAM-A occurs often, check out the cause and take necessary actions according to the table below.

Item	Possible cause	Action	Page
Paper tray	Too many sheets of media are loaded.	Limit the amount of media in the tray so it is below the sheet limit indication inside the tray.	1-7
	The media guide position does not match the media size.	Adjust the media guide position to match the media size.	1-7
Inside of the printer	The print media is stuck inside the printer.	Remove the stuck media.	6-4
	The print media remains behind the back cover or inside the media feeder cover.	Remove the media remains.	6-6
Media	The print media has become damp since it is left for a long period without being used.	Use media fresh from the package.	1-4
	Thin or thick media out of specifications has been used.	Use media that meets specifications.	1-4

1.3.2 Removal Procedure for JAM-B

Remove the jammed media according to the procedure below.

 CAUTION
The inside of the machine becomes very hot. Do not touch the parts with a “” label (means hot surface). Touching a part with a “” label (means hot surface) could result in a burn.

Removal procedure for JAM-B

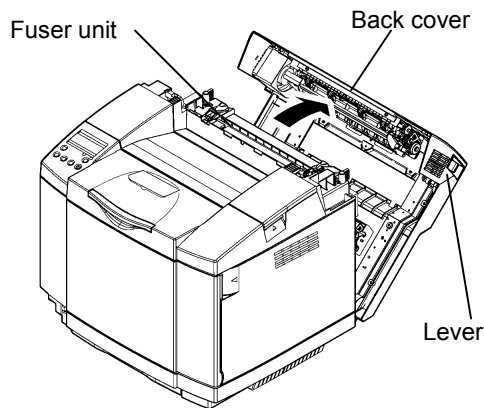

- (a) Pull the lever on the Back cover to unlock the back cover, and open the back cover until it stops.
- **Keep the top cover fully open during the replacement work.**

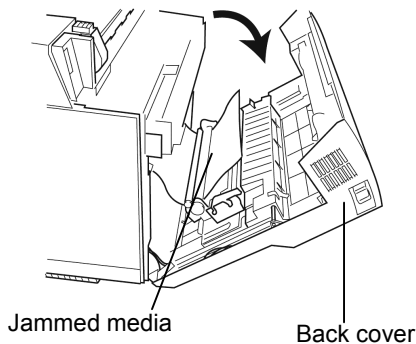

- (b) Remove the jammed media.
- **The toner on the paper is not fixed. Pay attention not to soil your hands or clothes.**
 - **Never touch the transfer drum. Otherwise, printing quality may be degraded.**

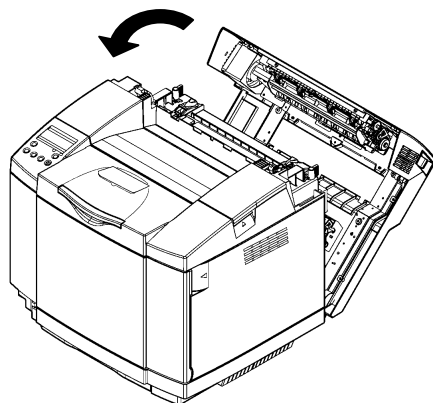

- (c) Close the back cover and push it until it locks.
- **While closing, keep holding the back cover until you close it to the locked position.**

If JAM-B occurs often



If JAM-B occurs often, check out the cause and take necessary actions according to the table below.

Item	Possible cause	Action	Page
Back cover	The back cover is not firmly shut.	Open the back cover and close it again.	6-6
Inside of the printer	There remains a jammed media.	Remove the remaining media.	6-6
Media	The print media has become damp since it is left for a long period without being used.	Use media fresh from the package.	1-4
	The edge of the media has been distorted.	Remove the edge-distorted media from the paper tray, or replace such media with new ones fresh from the package.	1-4 1-7
	The wire side of a two-sided paper is printed.	Load the paper with the felt side facing upward.	–
	Thin or thick media out of specifications has been used.	Use media that meets specifications.	1-4
Installation environment	The place around the printer is too hot.	Keep the printer away from heaters or office equipment generating heat.	Setup Guide
	The printer is too cold.	Print after the printer becomes accustomed to the room temperature, particularly in winter.	Setup Guide

1.3.3 Removal Procedure for JAM-C

Remove the jammed media according to the procedure below.

The procedure for resolving JAM-C instructs you, after letting you remove one sheet of media, to search for more media in accordance with the subsequent steps. There may be cases when a few sheets of media remain inside the printer.

 CAUTION
The inside of the machine becomes very hot. Do not touch the parts with a “  ” label (means hot surface). Touching a part with a “  ” label (means hot surface) could result in a burn.

Removal procedure for JAM-C

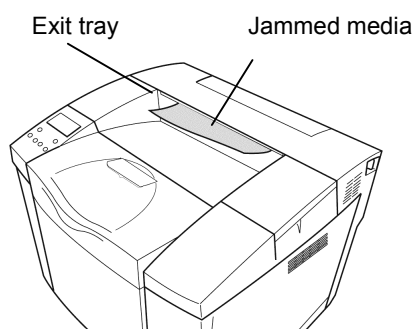

(a) Carefully pull the jammed media toward yourself.

- Do not force to pull up the jammed sheet yet. The sheet may be torn, causing difficulty in removing the sheet.

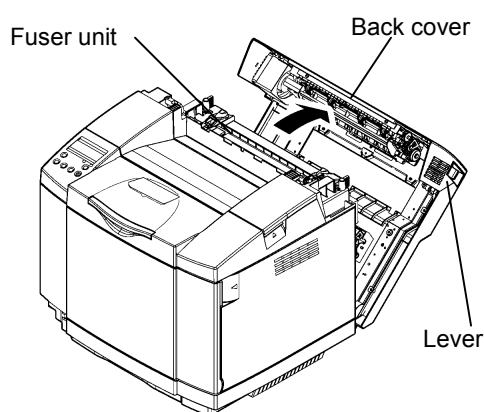

(b) Pull the lever on the Back cover to unlock the back cover, and open the back cover until it stops.

- Keep the top cover fully open during the replacement work.

Release levers

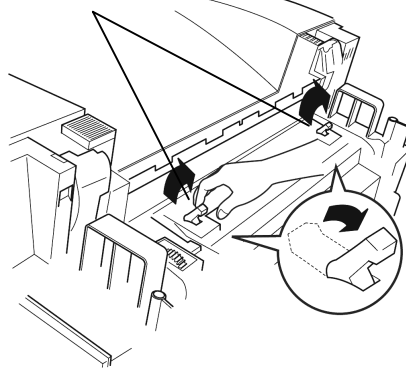

(c) Pull up the two green release levers.

- **Do not attempt to pull up the jammed sheet yet. The toner which has not been fixed may adhere to the fuser unit, causing print quality problems.**

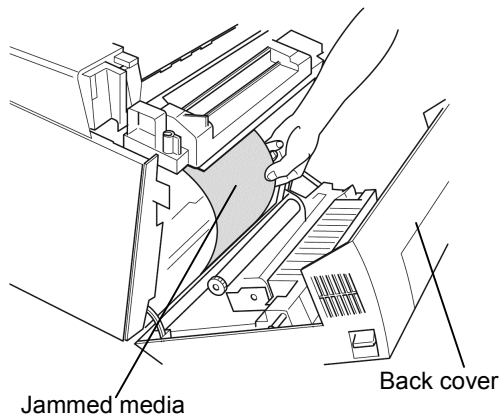

(d) Remove the jammed media.

- **The toner on the media is not fixed. Pay attention not to soil your hands and clothes.**
- **Do not touch the transfer belt. Otherwise, the print quality may be degraded.**

Release levers

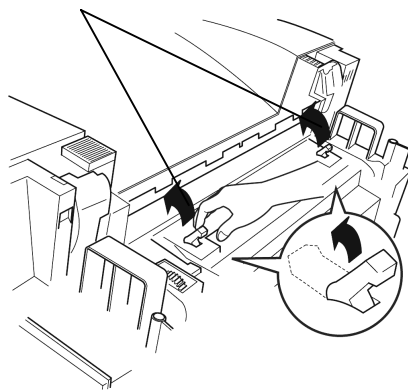

(e) Pull down the two green release levers.

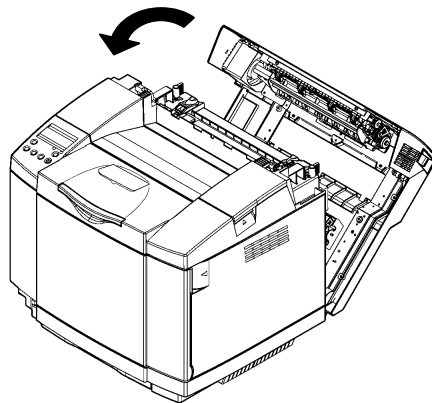

(d) Close the back cover.

If JAM-C occurs often

If JAM-C occurs often, check out the cause and take necessary actions according to the table below.

Item	Possible cause	Action	Page
Back cover	The back cover is not firmly shut.	Open the back cover and close it again.	6-8
Inside of the printer	There remains a jammed media.	Remove the remaining media.	6-8
Fuser unit	The media is stuck on the fuser roller.	Remove the media. In addition, a difference between the grain (orientation of paper fiber) and the formfeed direction may cause frequent jams. Use of the media having portrait grain is recommended.	6-8 1-4
Media	The print media has become damp since it is left for a long period without being used.	Use media fresh from the package.	1-4
	The edge of the media has been distorted.	Remove the edge-distorted media from the paper tray, or replace such media with new ones fresh from the package.	1-4 1-7
	The wire side of a two-sided paper is printed.	Load the paper with the felt side facing upward.	–
	Thin or thick media out of specifications has been used.	Use media that meets specifications.	1-4
Installation environment	The place around the printer is too hot.	Keep the printer away from heaters or office equipment generating heat.	Setup Guide
	The printer is too cold.	Print after the printer becomes accustomed to the room temperature, particularly in winter.	Setup Guide

1.3.4 Removal Procedure for JAM-D

Remove the jammed media according to the procedure below.

The procedure for resolving JAM-D instructs you, after letting you remove one sheet of media, to search for more media in accordance with the subsequent steps. There may be cases when a few sheets of media remain inside the printer.

CAUTION

During and immediately after the printer's operation, avoid touching the fuser unit and the area around it because they remain hot enough to cause burns. Turn off the printer and wait for 30 minutes or more. After the printer is fully cooled, remove the jammed media.

Removal procedure for JAM-D

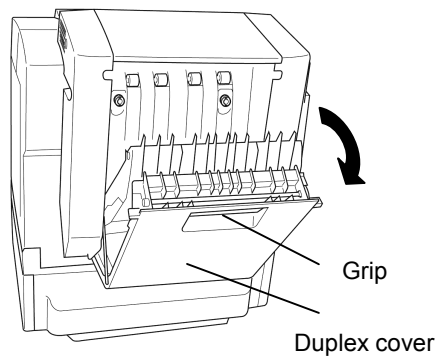

- (a) Hold the grip of the duplex cover, and open it backward to open.

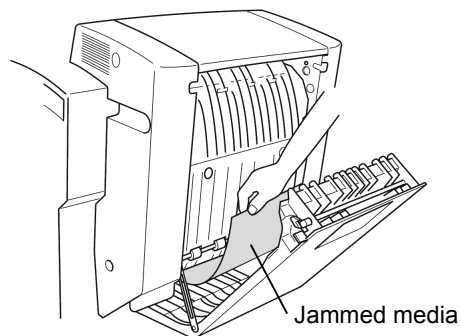

- (b) Carefully pull out the jammed media.

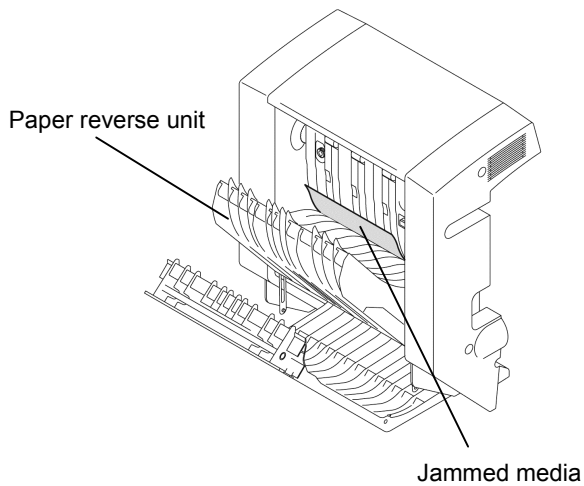

- (c) Pull the paper reverse unit and remove the jammed media.
- **Look into the opening and fully visually check that no media fragments are left in the bottom of the paper reverse unit.**

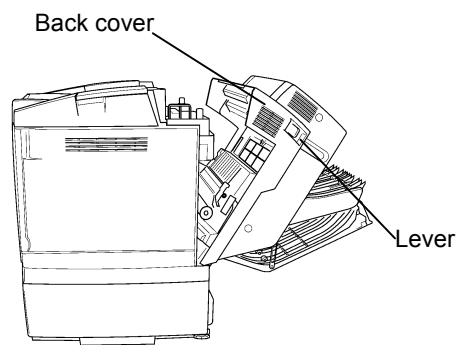

- (d) Pull the lever on the Back cover to unlock the back cover, and open the back cover until it stops.

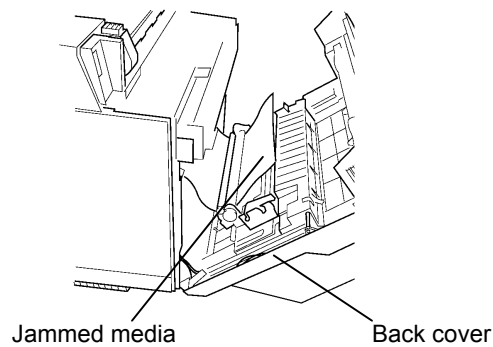

- (e) Remove the jammed media.
- **The toner on the paper is not fixed. Pay attention not to soil your hands or clothes.**
 - **Never touch the transfer drum. Otherwise, printing quality may be degraded.**

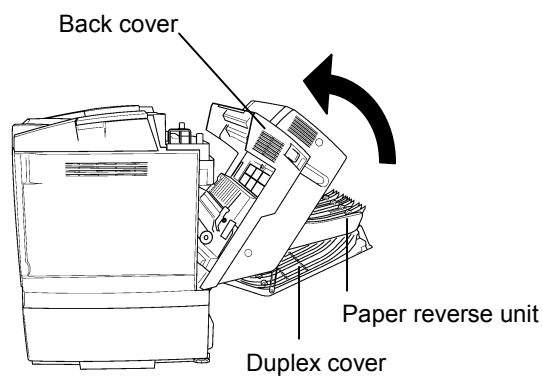

- (f) Close the paper reverse unit and the duplex cover.
- (g) Close the back cover and push it until it locks.
- **While closing, keep holding the back cover until you close it to the locked position.**

If JAM-D occurs often

If JAM-D occurs often, check out the cause and take necessary actions according to the table below.

Item	Possible cause	Action	Page
Duplex cover	The duplex cover is not firmly shut.	Open the duplex cover and close it again.	6-11
	There remains a jammed media.	Remove the remaining media.	6-11
	There remains a jammed media deep in the duplex unit.	Open the paper reverse unit and remove the remaining media.	6-14
Media	Thick media out of specifications has been used.	Use paper of 60 to 105 (g/m ²)/16 to 28 (lb. bond) mass for duplex printing.	1-4
	Other media out of specifications has been used.	Use media that meets specifications.	1-4

1.3.5 Removal Procedure for JAM-E

Remove the jammed media according to the procedure below.

The procedure for resolving JAM-E instructs you, after letting you remove one sheet of media, to search for more media in accordance with the subsequent steps. There may be cases when a few sheets of media remain inside the printer.

 CAUTION
During and immediately after the printer's operation, avoid touching the inside of duplex cover because it remains hot enough to cause burns. Turn off the printer and wait for 30 minutes or more. After the printer is fully cooled, remove the jammed media.

Removal procedure for JAM-E

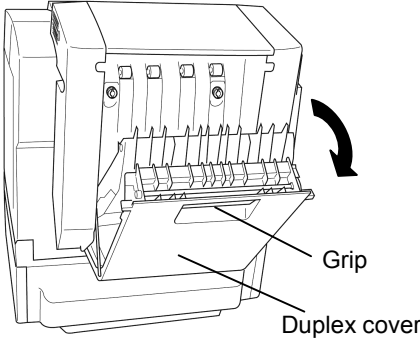
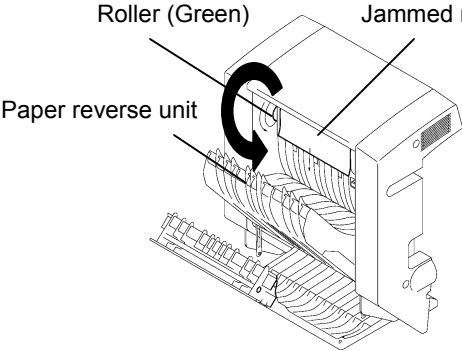
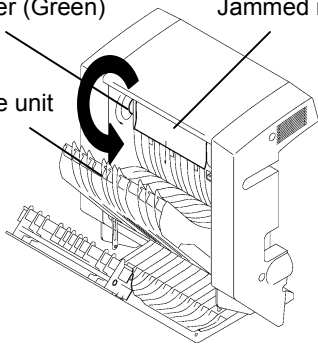
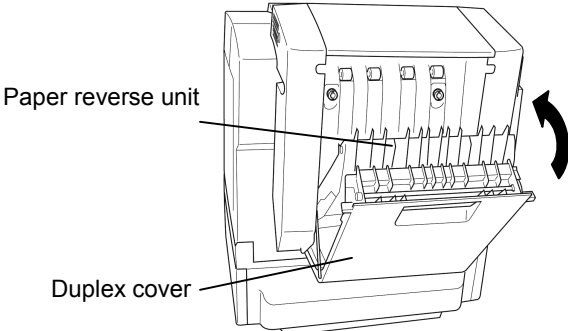
- 
- (a) Hold the grip of the duplex cover, and open it backward to open.
- 
- (b) Pull the paper reverse unit .
- 
- (c) Turn the green roller and send out the media remaining, if any, inside the duplex cover.
- 
- (f) Close the paper reverse unit and the duplex cover.

If no jammed media can be found in steps (c):

Open the back cover according to the removal procedure for JAM-C, and find out the jammed media. (page 6-8)

If JAM-E occurs often

If JAM-E occurs often, check out the cause and take necessary actions according to the table below.

Item	Possible cause	Action	Page
Inside of the printer	There remains a jammed media.	Remove the remaining media.	6-8
Duplex cover	The duplex cover is not firmly shut.	Open the duplex cover and close it again.	–
	There remains a jammed media.	Remove the remaining media.	6-14
	There remains a jammed media inside the paper reverse unit.	Open the paper reverse unit and remove the remaining media.	6-11
	Setscrews are not pushed in properly.	Push in the setscrews after tightening them.	Option Setup Guide
Media	Thick media out of specifications has been used.	Use paper of 60 to 105 (g/m ²)/16 to 28 (lb. bond) mass for duplex printing.	1-4
	Other media out of specifications has been used.	Use media that meets specifications.	1-4

2. Actions on Print Quality Problems

Take appropriate actions on print quality problems according to symptoms.

- Overall print is lighter than normal print, fill area on graphics show blank areas, white stripes appear in the printout, or small characters or hairlines do not print sharp.

Possible cause	Action	Page
A toner cartridge is becoming empty.	This symptom may occur when printing a large image. Replace the toner cartridge for applicable color.	2-3
More than one sheet has been picked.	Print again.	—
The media is damaged or extremely dry.	Use new print media fresh from its package.	1-4
The media is not in compliance with the printer's specifications.	Use the media in compliance with the printer's specifications.	1-4
The media type specified on the printer driver is incorrect.	Change the media type setting to the correct one.	1-11 *
Save Toner is enabled on the printer driver.	Turn off Save Toner.	*
The print mode on the printer driver is set to Standard or High Speed.	Set the print mode to High Quality.	1-14 *
The original graphic image is light in itself.	Increase the density value on the printer driver.	*

* See the printer driver help for further information (contained in the CD-ROM).

- Projections are dark or blurry. (OHP film or transparency)

Toner has peeled off. (thick paper or label)

Too glossy. (Plain paper)

Possible cause	Action	Page
An incorrect media type is specified on the printer driver.	Match the media type with the print media.	1-11 *

* See the printer driver help for further information (contained in the CD-ROM).

- Printing is too thick, black stripes appear, the image or background is dirty, or black characters or lines are blurry.

Possible cause	Action	Page
The photosensitive belt is damaged or deteriorated.	Replace the belt cartridge.	2-5
The printer contains jammed media.	Remove the jammed media.	6-2
The media is damp.	Use new print media fresh from its package.	1-4
The black color is generated from a mix of color toners.	On the printer driver, turn on Black Generation.	*
The original graphic image is thick in itself.	Decrease the density value on the printer driver.	*

* See the printer driver help for further information (contained in the CD-ROM).

- The reverse side of the print media is dirty.

Possible cause	Action	Page
The inside of the printer was stained with the toner powder when you removed the jammed media.	Print several sheets to remove the toner powder.	–

- The overall print quality is poor, or images are printed significantly different from displayed colors.

Possible cause	Action	Page
The quality of print data is low.	Change the Color setting on the printer driver.	1-15 *

* See the printer driver help for further information (contained in the CD-ROM).

3. Actions on Incorrect Print Results

Take appropriate actions on incorrect print results according to symptoms.

- Meaningless character strings are printed, or the printout crashes.

Possible cause	Action	Page
You are using the printer driver for different printer.	Use the correct printer driver for this printer.	*
You have installed the printer driver for different OS.	Delete and re-install the printer driver for the OS in use.	*
You have clicked the Cancel button in the print window or closed the print window.	Printing has been canceled. Print again.	—
You are attempting to print a document with a huge amount of image data.	Print the document on a page by page basis. Alternatively, increase free space in the hard disk of the PC.	—

* See the printer driver help for further information (contained in the CD-ROM).

- Data is not completely printed out, the line break positions are incorrect, or the page is printed out in an incorrect orientation.

Possible cause	Action	Page
The size of the print media does not match the page size of the document or the Print Size specified on the printer driver.	Load the media the size of which matches the page size of the document and the Print Size specified on the printer driver.	*
When creating a document, you selected another printer (printer driver).	Before printing, preview and check the document layout.	–
An error occurred on the PC.	Resolve the error, and print again.	–
A printer time-out occurred.	In the menu on the printer's control panel, increase the time-out value. Note: If you attempt to print a complex document, a time-out may occur in a few cases when the reception of print data exceeds the time-out setting.	5-15
A processing time-out occurred in the local connection mode.	On the printer driver, increase the time-out value. Note: If you attempt to print a complex document, a time-out may occur in a few cases when the sending of print data exceeds the time-out setting.	*
The print data is printed without being spooled.	On the printer driver, specify spooling. Note: If you attempt to print a document with a huge amount of image data, printing without spooling may occur in a few cases.	*

* See the printer driver help for further information (contained in the CD-ROM).

- Black and white (gray scale) images are printed in color.
Color images are printed in black and white (gray scale).

Possible cause	Action	Page
Incorrect color mode is set on the printer driver.	For black and white printing, clear the "Color Print" check box. For color printing, set the "Color Print" check box to on.	*

* See the printer driver help for further information (contained in the CD-ROM).

4. Actions on Abnormal Printer Operation

Take appropriate actions on printer troubles according to symptoms.

- The printer is not fed power.

Possible cause	Action	Page
The main power switch is not turned on.	Turn on the main power switch.	1-2
The power cord is not connected.	Connect the power cord.	Setup Guide
The power cord is damaged.	Ask your dealer or service representative to replace the power cord.	–
The wall outlet is not supplied with electricity.	Check the circuit breaker and other switches so that the wall outlet is supplied with electricity.	–

- Control panel indications are incorrect.

Possible cause	Action	Page
You have incorrectly turned on the printer.	Turn off the main power switch, wait for five seconds or more, and then turn on the main power switch again.	1-2 1-3

- Impossible to print.

	Possible cause	Action	Page
Printer	The printer is in the status in which printing is not available (symptom: ERROR lamp on).	Take actions according to the LCD message on the printer's control panel.	4-3
	The printer is offline (symptom: ONLINE lamp off).	Press the ONLINE key to enter online mode. (The ONLINE lamp lights.)	4-2
	A printer time-out occurred.	In the menu on the printer's control panel, increase the time-out value.	5-15
PC	You are using the printer driver for a different printer.	Use the printer driver for this printer.	*
	You have installed the printer driver for a different OS.	Delete and re-install the printer driver for the OS in use.	*
	You are attempting to print a document with a huge amount of image data.	Print the document on a page by page basis. Alternatively, increase free space in the hard disk of the PC.	—
Connection	The USB cable is not connected.	Make sure that the USB cable is connected.	Setup Guide
	A processing time-out occurred on the PC.	Increase the time-out value on the printer driver.	*
Others	You have clicked the Cancel button in the printer window or closed the print window.	Printing has been canceled. Print again.	—

* See the printer driver help for further information (contained in the CD-ROM).

- Printing takes much time.

	Possible cause	Action	Page
PC	On the printer driver, you have selected a media type other than plain paper.	Printing on a media other than plain paper takes twice or more times as long as printing on plain paper.	1-11 *
	The processing speed of the PC is slow.	Improve the CPU performance, memory capacity, and free disk space on the PC. Note: Printing a document with a huge amount of image data may take much time.	Setup Guide
	On the printer driver, you have set the print mode to High Quality.	Set the print mode to Standard or High Speed.	1-14 *
	The processing power of the PC is low.	Review the CPU performance, memory size, and hard disk capacity. Printing a document containing graphics or images may take much time.	Setup Guide

* See the printer driver help for further information (contained in the CD-ROM).

Appendixes

Appendix A Specifications	A-2
Appendix B Consumables	A-4
Appendix C Print Area	A-6
Appendix D Notes on Moving the Printer	A-7
Appendix E Checking Printer's Versions	A-8

Appendix A Specifications

Mainframe

Item	Description
Print method	Electrophotographic (Semiconductor laser method)
Resolution	23.6 × 23.6 dots/mm (Ref.: 600 × 600 dpi)
Colors	Four colors (black, yellow, magenta and cyan)
Print speed at multicopies print	8 sheets/minute in color, 31 sheets/minute in monochrome (condition: A4 plain paper)
First print time (from completion of data reception)	19 seconds in color, 13 seconds in monochrome (condition: A4 plain paper)
Warm-up time	No greater than 45 seconds (at 22°C, with the rated voltage input)
Media feed method	Up to two paper trays installable at a time: Standard tray for about 250 sheets + optional tray for about 530 sheets
Media output method	Face down: About 250 sheets
Media types	Plain paper, OHP transparencies, label paper, thick paper, and envelope
Mass of media	60 to 210 g/m ² , 16 to 55 lb. bond
Media size	Fixed scale: A4, A5, B5 (ISO), B5 (JIS), Letter, Half Letter, Executive, Commercial #10, International DL, and Legal*1 User-defined (W × L): 104.8 to 215.9 × 210 to 297 or 355.6*1 (mm) 4.13 to 8.50 × 8.27 to 11.69 or 14.00*1 (inch)
Page description language	JBIG
Printer memory	64MB
Interface	USB2.0 (Full speed: 12Mbps)
Printer drivers (standard accessory)	One for Windows 98/ ME/ 2000/ XP/ 4.0
Environmental conditions	Temperature 10 to 32.5°C, humidity 20 to 80% (Recommended: Temperature 17.5 to 27°C, humidity 50 to 70%)
Operation noise	66 dB*2 or below
Input power requirements	220-240VAC, 50 Hz ±2Hz
Power consumption	1,300 W maximum, 15 W or below in sleep mode
Dimensions (W × D × H)	480 × 420 × 385 (mm), 18.9 × 16.5 × 15.2 (inch)
Mass (with consumables installed)	Approx. 31.5 kg, 69.4 lb

*1 Requires optional paper tray capable of handling up to legal-size media in Tray 1.

*2 Sound Power Level

Options

Paper Feeder (PAPER FEED UNIT Type 1000)

Item	Description
Media size	A4☐, Letter (8½ × 11)☐
Dimensions (W x D x H)	460 × 466.5 × 185 (mm), 18.1 × 18.4 × 7.3 (inch)
Mass of media	60 to 105 g/m ² , 16 to 28 lb. bond
Mass (with consumables installed)	Approx. 6.0 kg, 13.2 lb

Duplex Unit (AD460)

Item	Description
Media size	A4☐, Letter (8½ × 11)☐
Dimensions (W x D x H)	345 × 185 × 406 (mm), 13.6 × 7.3 × 16.0 (inch)
Mass of media	60 to 105 g/m ² , 16 to 28 lb. bond
Mass (with consumables installed)	Approx. 5.2 kg, 11.5 lb

Appendix B Consumables



Our products are engineered to meet the highest standards of quality and functionality. When purchasing expendable supplies, we recommend using only those specified by an authorized dealer.

Toner cartridge

Toner cartridge	Average printable number of pages per cartridge
Black	9,800 pages *1 (8,200 pages *2)
Cyan	6,500 pages *3 (6,500 pages *4)
Magenta	6,500 pages *5 (6,500 pages *6)
Yellow	6,500 pages *7 (6,500 pages *8)

*1 Based on a standard A4/letter 5% test chart when printing continuously in black and white.

*2 Based on a standard A4/letter 5% test chart when printing a series of two-page print jobs in black and white.

*3 Based on a standard A4/letter 5% test chart when printing continuously in cyan.

*4 Based on a standard A4/letter 5% test chart when printing a series of two-page print jobs in cyan.

*5 Based on a standard A4/letter 5% test chart when printing continuously in magenta.

*6 Based on a standard A4/letter 5% test chart when printing a series of two-page print jobs in magenta.

*7 Based on a standard A4/letter 5% test chart when printing continuously in yellow.

*8 Based on a standard A4/letter 5% test chart when printing a series of two-page print jobs in yellow.

Note:

- After the message "Check Toner xxxx" appears where xxxx stands for black, cyan, magenta or yellow, about 250 pages can still be printed (when continuously printing a 5% chart on A4/letter size paper). We recommend that you change the toner cartridge soon.
- If toner cartridges are not changed when necessary, printing will become impossible. We recommend keeping a stock of cartridges or purchasing them soon.
- The actual number of printable pages varies depending on the image volume and density, number of pages to be printed at a time, paper type and paper size used, and environmental conditions such as temperature and humidity.
- Toner cartridges may need to be changed sooner than indicated above due to deterioration over the period of use.
- Toner cartridges (consumables) are not covered by warranty. However, if there is problem, contact the store where they were purchased.
- Numbers of pages that can be printed using the toner cartridge supplied with this printer is as follows:

Toner cartridge	Average printable number of pages per cartridge
Black, Cyan, Magenta, Yellow	1,500 pages

Waste toner pack

Name	Average printable number of pages
Waste Toner Bottle Type 140	11,000 pages *1 (9,200 pages *2) 2,750 pages *3 (2,300 pages *4)

*1 Based on a standard A4/letter 5% test chart when printing continuously in black and white.

*2 Based on a standard A4/letter 5% test chart when printing a series of two-page print jobs in black and white.

*3 Based on a standard A4/letter 5% test chart when printing continuously in color.

*4 Based on a standard A4/letter 5% test chart when printing a series of two-page print jobs in color.

Note:

- After the message "Replace WT.Pack" appears, about 200 pages can still be printed. (When continuously printing at 5% test chart on A4/letter□ in black and white).
- The actual number of printable pages varies depending on the image volume and density, number of pages to be printed at a time, paper type and paper size used, and environmental conditions such as temperature and humidity.
- If waste toner pack is not changed when necessary, printing will become impossible. We recommend keeping a stock of waste toner pack or purchasing one soon.

Belt cartridge

Name	Average printable number of pages
Photo Conductor Unit Type 140	60,000 pages *1 (27,000 pages *2) 15,000 pages *3 (9,000 pages *4)

*1 Based on a standard A4/letter 5% test chart when printing continuously in black and white.

*2 Based on a standard A4/letter 5% test chart when printing a series of two-page print jobs in black and white.

*3 Based on a standard A4/letter 5% test chart when printing continuously in color.

*4 Based on a standard A4/letter 5% test chart when printing a series of two-page print jobs in color.

Note:

- After the message "Replace Belt CG" appears in the second line of the LCD, about 750 pages can still be printed. (When continuously printing at 5% test chart on A4/letter□ in black and white).
- The actual number of printable pages varies depending on the image volume and density, number of pages to be printed at a time, paper type and paper size used, and environmental conditions such as temperature and humidity.
- If the belt cartridge is not changed when necessary, the quality of printing is not guaranteed. We recommend keeping a stock of belt cartridge or purchasing one soon.
- Belt cartridge (consumables) is not covered by warranty. However, if there is problem, contact the store where they were purchased.

Appendix C Print Area

The following shows the print area for this printer. Be sure to set the print margins correctly by the application.

- Paper

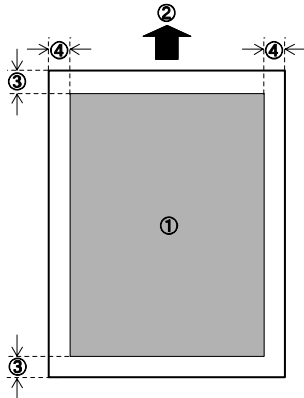

- ① Print area
- ② Feed direction
- ③ Approx. 5 (mm), 0.20 (inch)
- ④ Approx. 4 (mm), 0.16 (inch)

Note: The print area may vary depending on the paper size, printer language and printer driver settings.

- Envelope

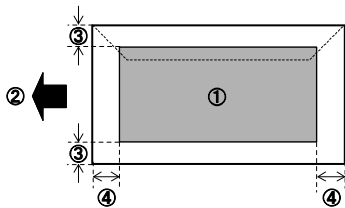

- ① Print area
- ② Feed direction
- ③ Approx. 4 (mm), 0.16 (inch)
- ④ Approx. 5 (mm), 0.20 (inch)

Note: The print area may vary depending on the paper size, printer language and printer driver settings.

Appendix D Notes on Moving the Printer

When moving the installed printer, note the following.

- **When carrying the printer**



CAUTION

The printer weights approximately 31.5 kg/69.4 lb. When moving the printer, use the inset grips on both sides, and lift slowly. The printer will break or cause injury if dropped.

- Remove the Paper Feeder option and the Duplex Unit option, if any, from the printer before carrying it.
- When carrying the printer, keep it horizontal. If you tilt the printer, consumables (oil and toner) may spill in the printer, causing trouble.
- Subjecting the printer to shocks or strong vibration may cause it not to work. When carrying the printer on a cart, push it slowly and move the cart carefully.

- **When transporting the printer**

When transporting the printer, the consumables need to be removed and the inside of the printer need to be cleaned for repacking. These actions must be conducted by a qualified service engineer on a chargeable basis.

Appendix E Checking Printer's Versions

- **Firmware version of the printer:**
Check on the Config page printout (page 5-8). See encircled position in the figure below.

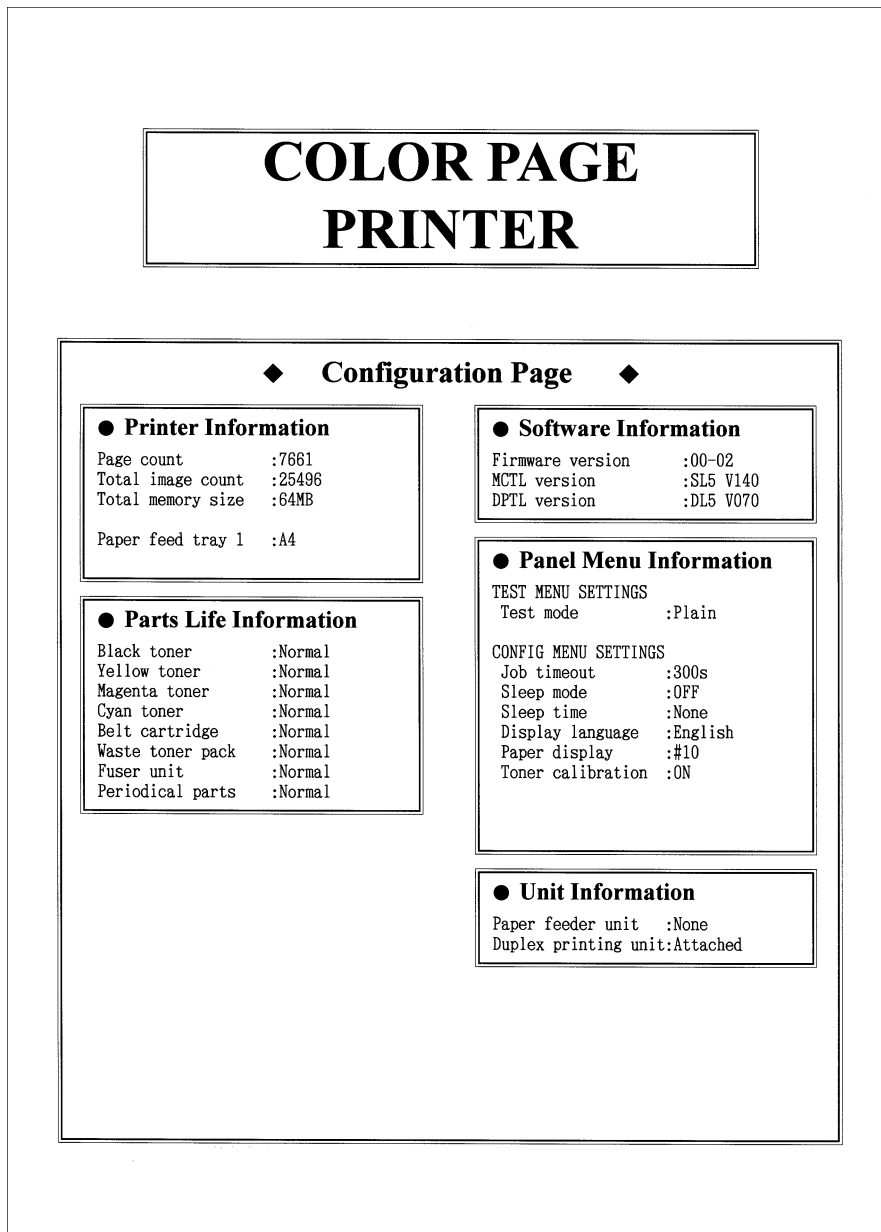

Model number: G132
GB  G132-8110